

LED OPERATORY LIGHT
Instructions For Use

DCI edge

OVERVIEW

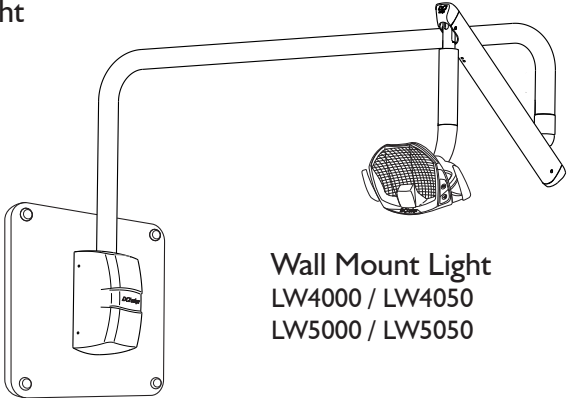
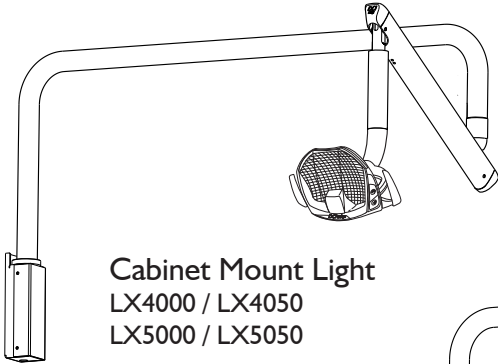
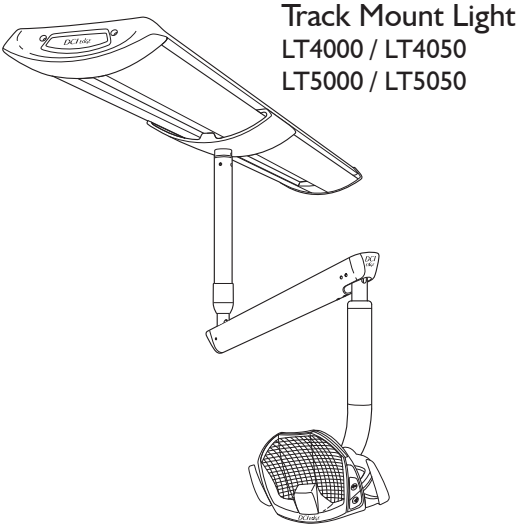
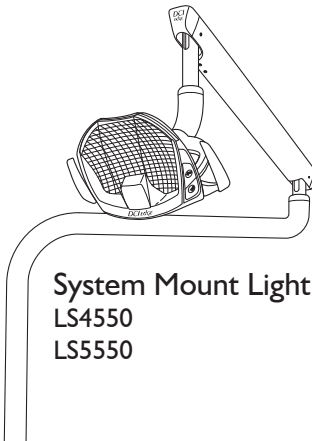
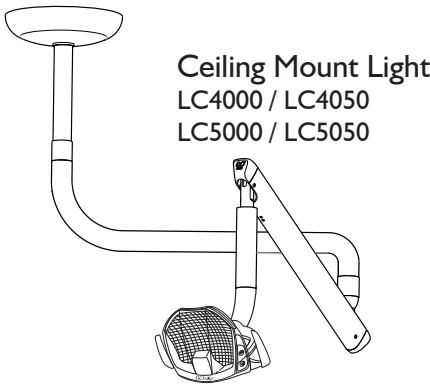
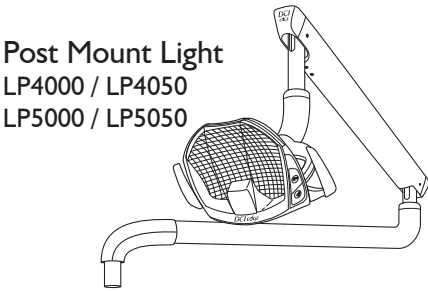

INTRODUCTION

SYMBOLS

The following symbols may be used throughout this product manual:



CAUTION: General Caution. Failure to carefully follow the described procedure may result in damage to the equipment.



WARNING: Failure to carefully follow the described procedure may result in damage to the equipment, the operator, and/or the operator.



ELECTRICAL HAZARD: Risk of electrical shock present. Ensure that power is disconnected before attempting this procedure.



NOTE: Take note of additional important information. Not a warning or caution.



Manufacturer



Manufacturing date



Waste Electrical and Electronic Equipment



Protective Earth (ground)



Alternating Current (AC)



Conforms to applicable European Directives (Essential Requirements)



Electrical Testing Lab



Advisable to consult accompanying documents



Power ON/OFF



Dimming



No Cure



Motion Sensor

TABLE OF CONTENTS

| | |
|--------------------------------|----|
| System Overview | 2 |
| Introduction | 3 |
| General Information | 4 |
| General Safety | 5 |
| Operation - Keypads | 6 |
| Operation - Range of Motion | 8 |
| Disinfection and Sterilization | 9 |
| Maintenance | 10 |
| Electromagnetic Compatibility | 13 |

GENERAL INFORMATION

INTENDED APPLICATION AND USE

The DCI Edge LED operatory light is a device intended to illuminate the oral cavity with a shadow reduced pattern generated by low voltage LEDs within a movable assembly which is accessible to the user. The device is designed to be mounted in a variety of ways suitable to accommodating the needs of a dental operatory environment. It is intended for use by dental professionals while performing dental procedures.

The dental light is classified as Class I device under rule FDA CFR 21, Class I device under Health Canada guidelines, and a Class I device under rule II of the MDD 93/42/EEC of Annex IX.

PRODUCT IDENTIFICATION

The DCI Edge LED operatory light can be identified by the label on the back side of the light head. This label states the model number, serial number, electrical specifications, manufacturing date, software version, and safety classifications.

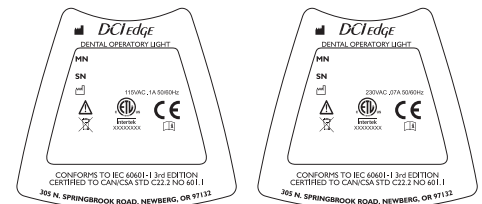

ELECTRICAL SPECIFICATIONS

| | | |
|--|----------|--|
| 115VAC | 230VAC | Fuses are labeled at point of use. Replace fuses only with type and rating as indicated below. |
| .1 Amps | .07 Amps | |
| 50-60Hz | 50-60Hz | Fuses are used in model numbers starting with LP: Fuse type GTL, glass cartridge 5x20mm Voltage and Current ratings 250V Operating speed Slow burn fuse (time delay) Breaking capacity 1 Amp |
| IEC Medical Classification I Operation: Continuous Splash Protection: IPX0 | | |

ENVIRONMENTAL CONDITIONS

| |
|---------------------------|
| Operating Conditions: |
| Temperature: 67-76° F |
| Humidity: 20-60% |
| Altitude: <5,000 m |
| Shipping conditions: |
| Temperature: -68 - 122° F |
| Humidity: 10-90% |

ELECTRICAL DEVICE INTERFERENCE

To guarantee the operational safety of electromedical devices, it is recommended that the operation of mobile radio telephones in the medical practice or hospital be prohibited. Strong EMI sources such as electrosurgery units or x-ray units may affect performance. If performance problems occur, move the light to another electrical circuit or physical location.

INCOMPATIBLE DEVICES

For safety reason, only DCI original devices and accessories approved for this product or accessories from third parties released by DCI may be used.

TECHNICAL DOCUMENTATION

The manufacturer will make available upon request circuit diagrams, component part lists, descriptions, and calibration instructions to technical personnel responsible for the installation and service of this equipment.

PRODUCT DISPOSAL

Contact your local, authorized dealer for disposal of this device to ensure compliance with your local environmental regulations.

PREVENTATIVE INSPECTION

The performance of the equipment can be affected by use over time. Periodically inspect the water and air lines for visible cracks or cuts, and inspect for loose fittings and fasteners which could lead to leaks or other poor performance characteristics. Inspect joints and tensioning screws as a regular maintenance item to ensure proper positioning of the device.

GENERAL SAFETY

WARNINGS & CAUTIONS



WARNING: This product must be disinfected before use.



CAUTION: Only authorized service technicians should attempt to service this equipment. Use of other than authorized technicians will void the warranty.



CAUTION: Use a licensed electrician for all wiring.



WARNING: To avoid risk of electric shock, this equipment must be connected only to supply mains with protective ground.



WARNING: Modification of this equipment is not allowed.



To isolate Mains power, use the Mains supply breaker in the breaker box.



WARNING: Failure to disinfect this device between patients could expose the user and patient to cross contamination and bioburden/biocontamination.



WARNING: Power cords and their associated parts cannot be substituted without increased risk of shock or fire. Use authorized replacement parts only. Power cords must be installed by qualified personnel. Ensure all service loops, strain reliefs and cord guards are in place and that line, neutral and ground wires are secured.

OPERATION - SERIES 4 KEYPADS

NORMAL OPERATION

Keypads are located on both sides of the light head and are easily accessible while grasping the handle on either side.

POWER: Press the **Power** key to turn the light ON or OFF.

INTENSITY: Press the **Intensity** key to toggle between HIGH/MEDIUM/LOW settings.

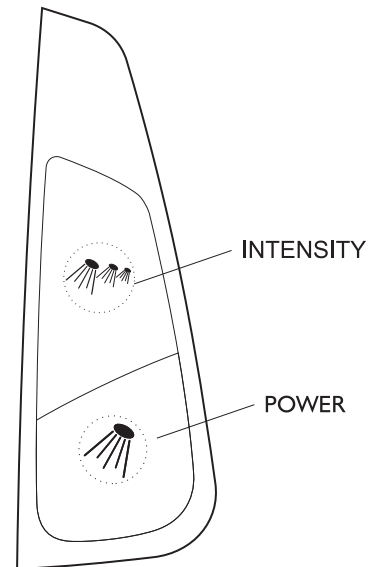

RIGHT KEYPAD
(LOCATED ON THE FRONT
OF THE LIGHT HEAD)

OPERATION - SERIES 5 KEYPAD AND SENSORS

KEYPADS

Keypads are located on both sides of the light head and are easily accessible while grasping the handle on either side.

POWER: Press the **Power** key to turn the light ON or OFF.

INTENSITY: Press the **Intensity** key to toggle between HIGH/MEDIUM/LOW settings.

NO CURE: Press the **No Cure** key to toggle the light from No Cure to Normal mode.

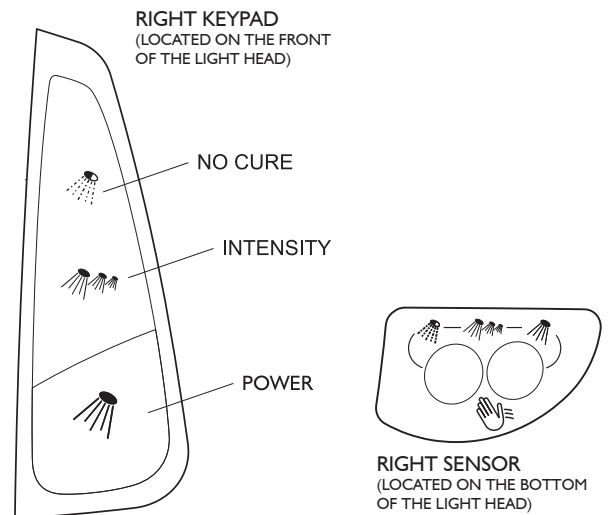

MOTION SENSORS

The Series 5 light head is equipped with two programmable motion sensors which are factory set to operate the Dimming (right sensor) and No Cure (left sensor) functions of the light.

Operate the sensor by waving your hand approximately 2 inches in front of the sensor with a deliberate motion which does not cross over to the other sensor.



NOTE: Direct sunlight shining into the motion sensors may cause unintended activation or deactivation. If the sensor reacts to direct sunlight in this manner, lower shades or disable the motion sensor.

PROGRAMMING MOTION SENSORS

The motion sensors can be independently assigned any of the three keypad functions.

ASSIGN NEW FUNCTION TO EACH SENSOR

- 1) Ensure that the light is off.
- 2) To assign a function to the right side sensor: Using the right side keypad, press and hold any key for 5 seconds to assign the function of that key to the sensor.
- 3) Repeat the same process using the left side keypad to assign a function to the left side sensor.

DISABLE SENSORS

- 1) Ensure that the light is off.
- 2) To disable the right side sensor: Using the right side keypad, press and hold the No Cure and Intensity keys simultaneously for 5 seconds.
- 3) Repeat the same process using the left side keypad to disable the left side sensor.

To restore the sensor to the previously held assignment, repeat the above steps or follow the instructions to assign a new function.

OPERATION - RANGE OF MOTION

LIGHT HEAD

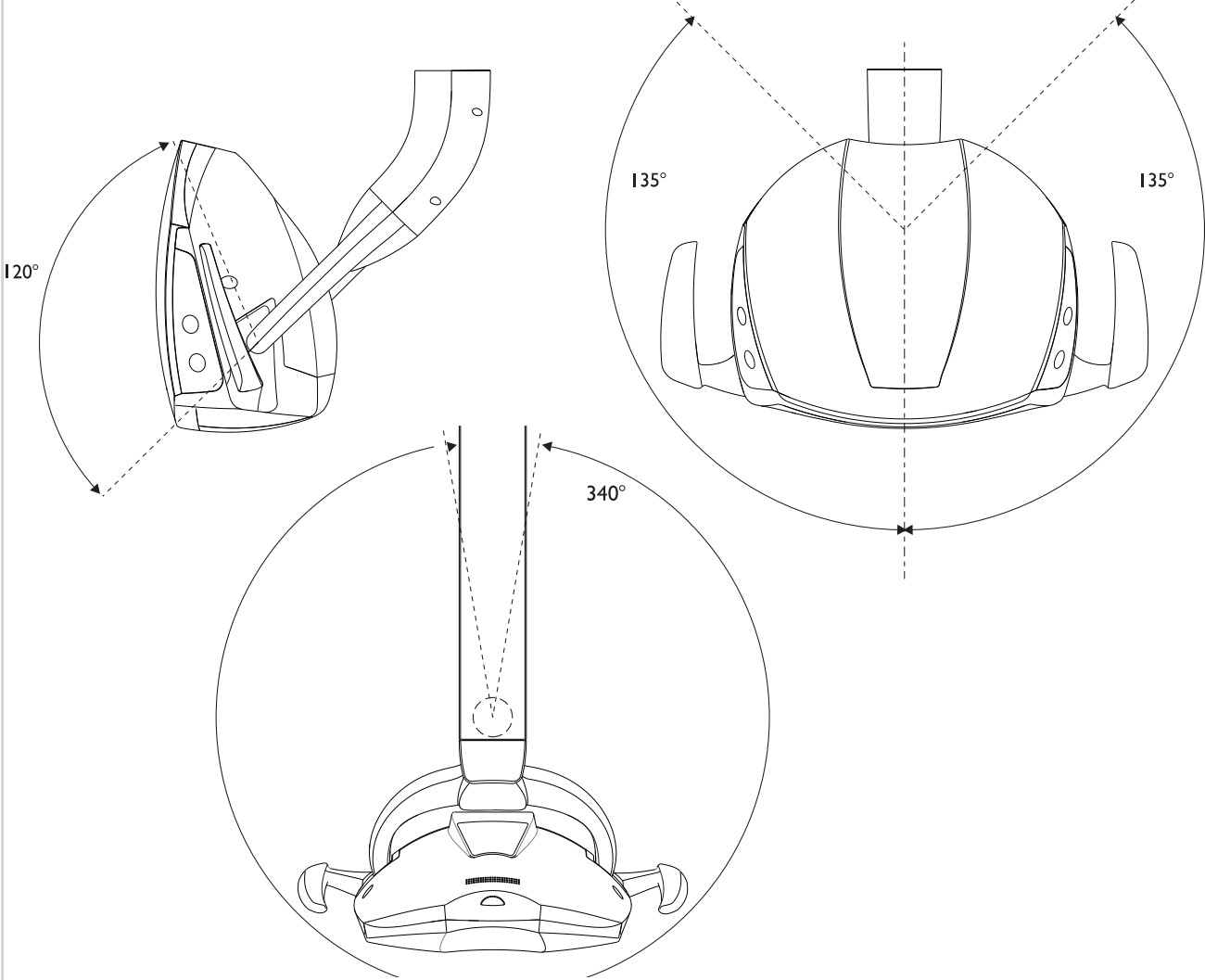

DISINFECTION

BARRIER TECHNIQUE

Wherever possible disposable barriers should be used and changed between patients. The barrier technique will ensure maximum long term durability of the surfaces and finishes of the equipment.

DISINFECTION

Infection Control in the dental office continues to be a high priority for our customers and end users. OSHA, the ADA and the CDC are also involved in this complex issue. The Manufacturer will not attempt to specify the required intervals for disinfection nor can it recommend the overall best surface disinfectant. Please refer to the Infection Control Recommendations published by the American Dental Association for further information. It is important to know the effectiveness of any chemical disinfectant against the various agents of infection that may be encountered.

CHEMICAL DISINFECTION

Regardless of the chemical disinfectant used, it is imperative that the equipment be thoroughly washed with mild soap and warm water at least once per day. This wash down will minimize the harmful effects of chemical disinfectant residues being allowed to accumulate on the equipment. When using chemical disinfectants, always pay strict attention to the manufacturer's disinfectant directions. When using concentrated disinfectants, measure the concentrate carefully and mix according to package directions. Disinfectant solutions that are relatively harmless to surfaces at their recommended strengths can be corrosive at higher than recommended dilution ratios.



CAUTION: These disinfectants will harm the surface finish of dental equipment and are not recommended:

- Strong Phenols/Phenol Alcohol combinations
- Sodium Hypochlorite/Household Bleach
- Sodium Bromide
- Strong Alcohol
- Household Cleaners (Dental Equipment Only)
- Citric Acids
- Iodophors
- Ammonium Chloride
- Accelerated Hydrogen (0.5%)

MAINTENANCE

GENERAL CLEANING

Equipment can be cleaned with a solution of mild detergent and warm water. A variety of surface disinfectants are available for use in dental treatment rooms. Some of these can cause discoloration of painted, plated or anodized surfaces with repeated use. This can be minimized by careful adherence to the disinfectant manufacturer's instructions and by frequent washing with soap and water.



CAUTION: Do not use powdered cleansers, scouring pads or abrasive scrubbers on any of the painted, plastic or metal surfaces of this dental unit. To remove dried-on material, use a soft-bristled brush and a solution of mild detergent.

REFLECTOR CLEANING

In the event that the reflector requires cleaning, follow the instructions below to avoid scratching the surface:

1. Saturate a clean, soft, lint-free cloth using mild detergent and warm distilled quality water.
2. Wipe the reflector gently with long horizontal or vertical strokes.
3. Use clean, dry, soft, lint-free cloth to dry the reflector.

SHIELD REPLACEMENT

The transparent shield is coated with a protective, anti-static and scratch resistant coating. Over time, the shield may still show the effects of disinfectants and cleaners. The shield may be removed by depressing the transparent button on the top surface of the light head and pulling the shield forward and away from the light head. Replace the shield by aligning both tabs at the bottom edge of the shield with the slots along the bottom edge of the front cover and then sliding the top tab until it engages in the top opening of the light head.

REMOVE SHIELD

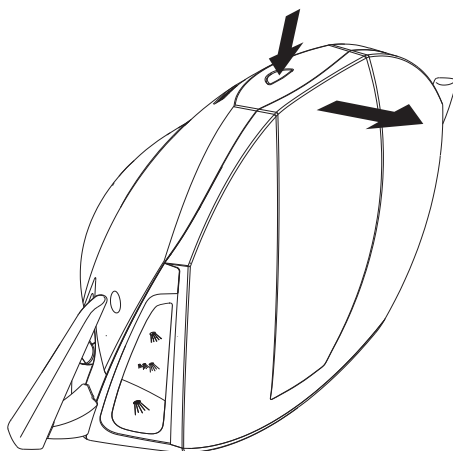

REPLACE SHIELD

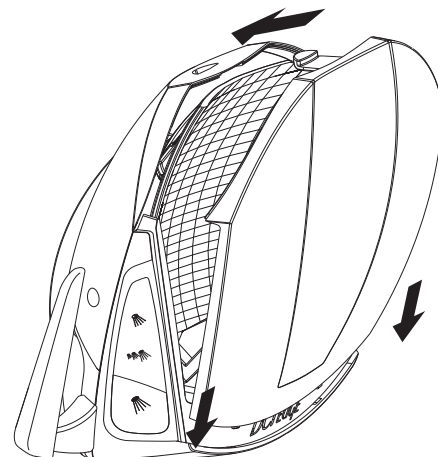

MAINTENANCE

TENSIONING

Adjust the tensioning of the 3 axes of rotation of the light head by tightening the set screw locations shown below:

- 1) Vertical axis rotation 7/64 hex wrench
- 2) Diagonal rotation of the light head 7/64 hex wrench
- 3) Tilt angle of the light head 5/64 hex wrench

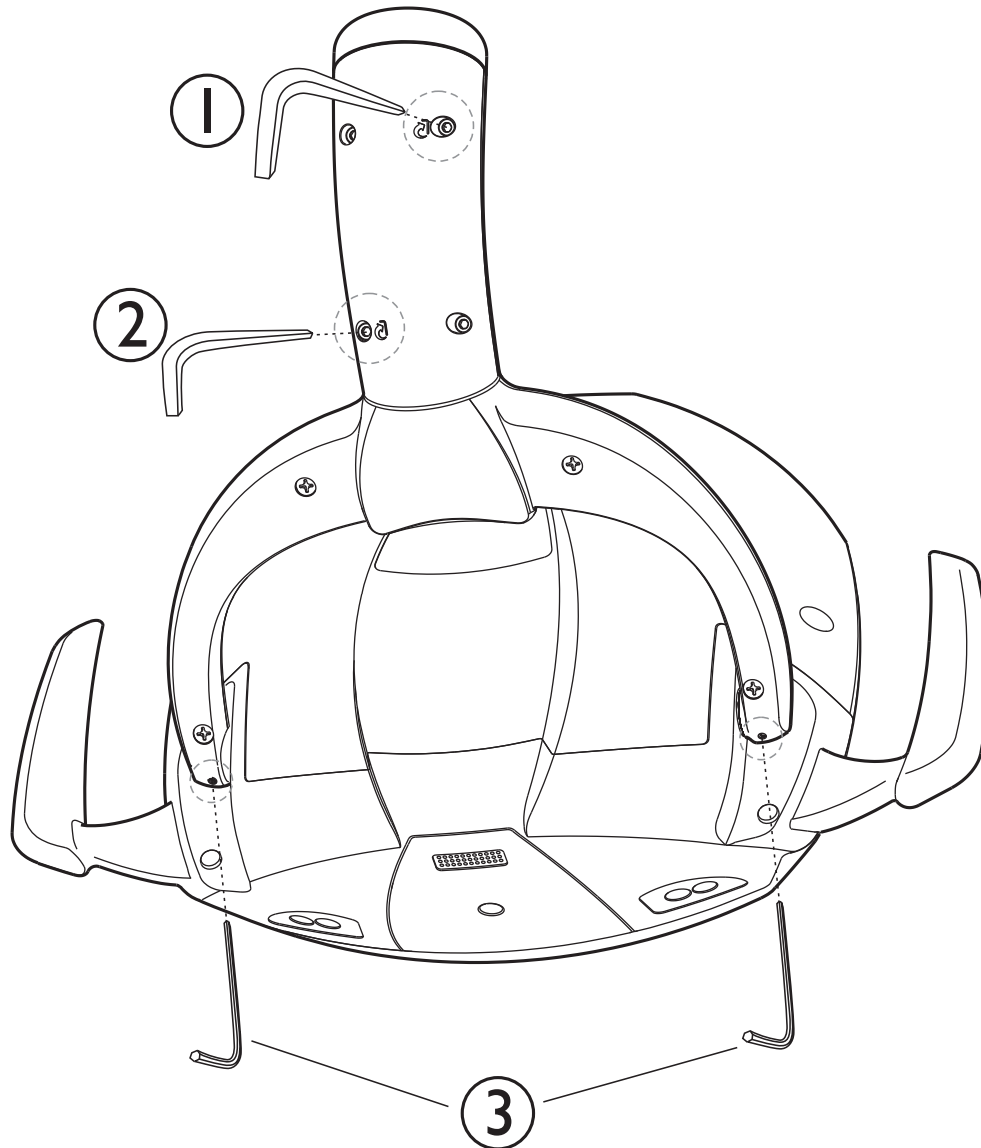



MAINTENANCE

FUSE AND BREAKERS

Under abnormal conditions, the circuit breaker or glass fuse interrupts the flow of electricity. If the circuit breaker trips, reset it by pushing the circuit breaker button or replacing the fuse as shown for the configurations below.

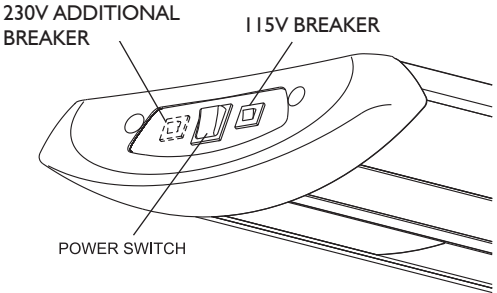
TRACK MOUNT



 **CAUTION:** All fuses are labeled at point of use. Replace fuses only with type and rating as indicated.

POST MOUNT LIGHT

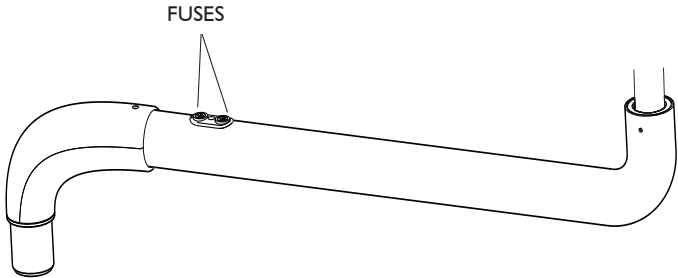

CEILING MOUNT

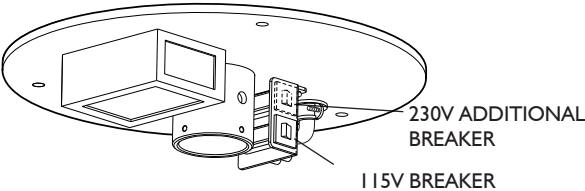

WALL MOUNT

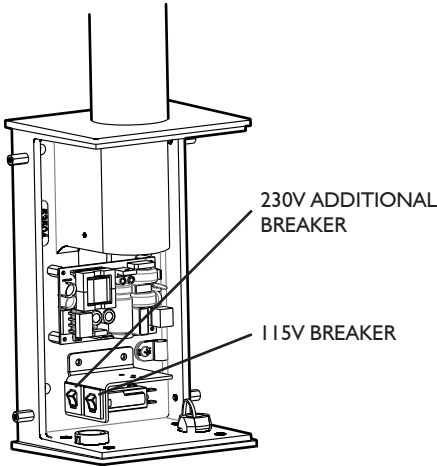

CABINET MOUNT

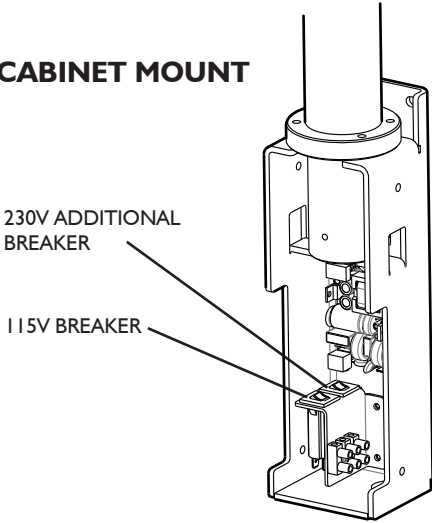

ELECTROMAGNETIC COMPATIBILITY

DEVICE COMPATIBILITY

ELECTRICAL MEDICAL

Electrical medical devices are subject to special EMC safety measurements and as a result the equipment must be installed according to the installation instruction manual.

PORTABLE ELECTRONIC DEVICES

Portable and mobile high frequency electronic communications equipment may interfere with electronic medical devices.

STATIC SENSITIVE DEVICES

Where labeled this equipment contains static sensitive devices that require special precautions when handling. At a minimum a grounded wrist strap that is connected to ground stud should be worn to reduce the possibility of damage to the light.

ACCESSORY USE

Using accessory devices not specified by DCI for use with their equipment may result in an increase of electromagnetic emissions and/or a decrease in electromagnetic immunity of the system.

INTERFERENCE FROM OTHER EQUIPMENT

If other equipment is used adjacent to or stacked with the DCI Edge equipment, the system must be observed to verify normal operation.

DCI EDGE LED OPERATORY LIGHT COMPLIANCE

This equipment has been tested and found to comply with the limits for medical devices in IEC 60601-1-2. These limits are designed to provide reasonable protection against harmful interference in a typical medical installation. In the event of interference, power the devices from separate mains supplies and/or increase the physical distance between devices. Contact Customer Service if you have any questions.

