

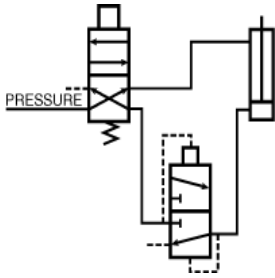

Quick Exhaust & Shuttle Valve

Typical "Quick Exhaust Valve" Applications



Rapid Retraction--- Double Acting Cylinder

In this circuit air is exhausted through a Quick Exhaust Valve that is **close coupled** to the cap end of the cylinder because the Quick Exhaust Valve has a greater exhaust capacity than the four-way Control Valve. Increased cylinder speed can be accomplished with a smaller and less expensive control valve.

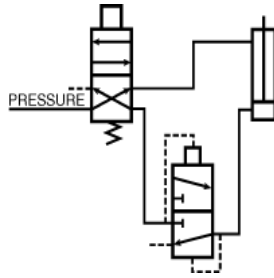

Dual Pressure Actuation of Double Acting Cylinder

This circuit utilizes a Quick Exhaust Valve and a three-way Control Valve to permit rapid extension of the cylinder at a high pressure. Retraction can be accomplished at a lower pressure, thus **saving air** and **increasing cylinder life**. Note: Line pressure must be 3 or 4 times greater than rod end pressure. Effective working pressure is the differential between the cap and rod end.

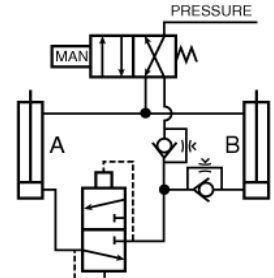

Bi-Directional Control of Two Double Acting Cylinders

This circuit provides maximum control with a minimum of valving. A large four-way control valve is not needed to permit the rapid retraction of cylinder A, as the Quick Exhaust Valve performs this function. The extension of Cylinders A and B and retraction of Cylinder B are controlled by Speed Control Valves.

Typical "Shuttle Valve" Applications

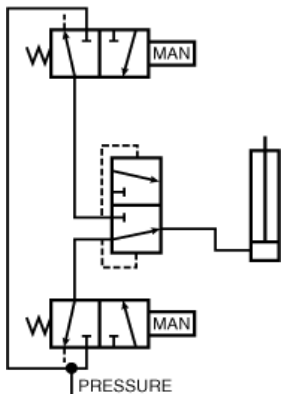

"OR" Circuit

The most common application of the Shuttle Valve is the "OR" Circuit. Here a cylinder or other work device can be actuated by either control valve. The valves can be manually or electrically actuated and located in any position.

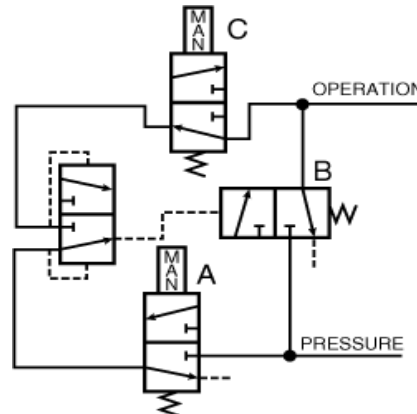

"Memory" Circuit

This circuit enables continuous operation once initiated. Pressure is delivered to the circuit when Valve A is actuated. This allows pressure to pass through the Shuttle Valve actuating Valve B. Pressure then flows through Valve B and also the other side of the Shuttle Valve which holds Valve B open for continuous operation. To unlock the circuit, Valve C must be opened to exhaust the circuit and allow Valve B to return to its normally closed position.

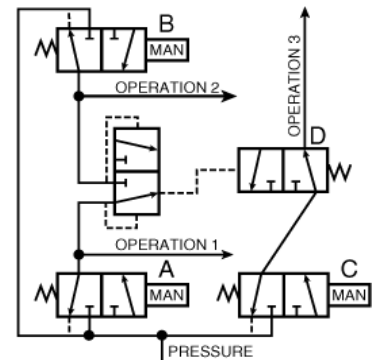

Interlock

This circuit prevents the occurrence of a specific operation while one or another operation takes place. When either Valve A or B is actuated to perform operation 1 or 2, Valve D is shifted to the closed position and prevents operation 3 from occurring.

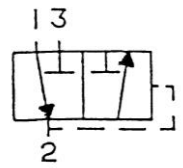

QUICK EXHAUST

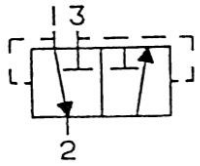

SHUTTLE VALVE

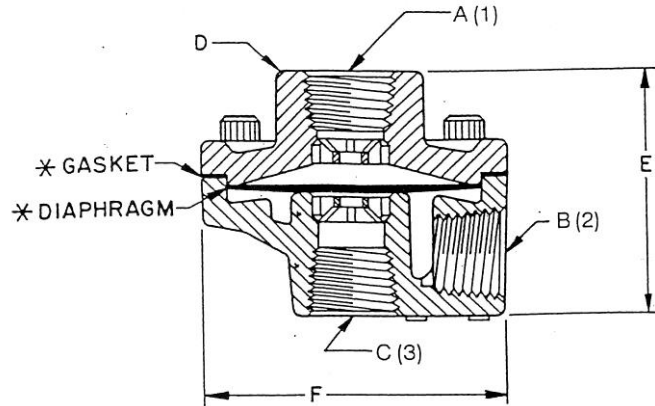

*Included In Service Kit.

PIPE PORT SIZE			Flow Capacity SCFM	Dimensions			Service Kits		
A (1)	B (2)	C (3)		D	E	F	Urethane	Viton	Teflon
1/8	1/8	1/8	70	7/8 Sq.	1 3/4	1 7/8	3640-8000	3650-8000	-
1/8	1/8	1/4	70	7/8 Sq.	1 3/4	1 7/8	3640-8000	3650-8000	-
1/4	1/4	1/4	90	7/8 Sq.	1 3/4	1 7/8	3640-8000	3650-8000	-
1/4	1/4	3/8	150	1 Hex	2 1/16	2 7/16	3340-0105	3340-0319	3340-0504
1/4	3/8	3/8	240	1 Hex	2 1/16	2 7/16	3340-0105	3340-0319	3340-0504
3/8	3/8	3/8	240	1 Hex	2 1/16	2 7/16	3340-0105	3340-0319	3340-0504
1/2	1/2	1/2	450	1 1/2	2 7/8	3 3/8	3475-0109	3475-0120	-
3/4	3/4	3/4	550	1 1/2	2 7/8	3 3/8	3475-0109	3475-0120	-

Operating Temperatures:

Urethane diaphragm units: -40°F to +180°F

Viton diaphragm units: -40°F to +400°F

Teflon diaphragm units: -110°F to +500°F

Operating Pressures:

Maximum: 150 psig air only

(200 psig for Teflon diaphragm units)

Minimum: 3 psig

(Suggested: 50 psig for Teflon diaphragm units)

CAUTION:

If it is possible that the ambient temperature may fall below freezing, the medium must be moisture free to prevent internal damage or unpredictable behavior.

WHEN SERVICING UNIT, TURN OFF AIR PRESSURE AND DEPRESSURIZE SYSTEM.