

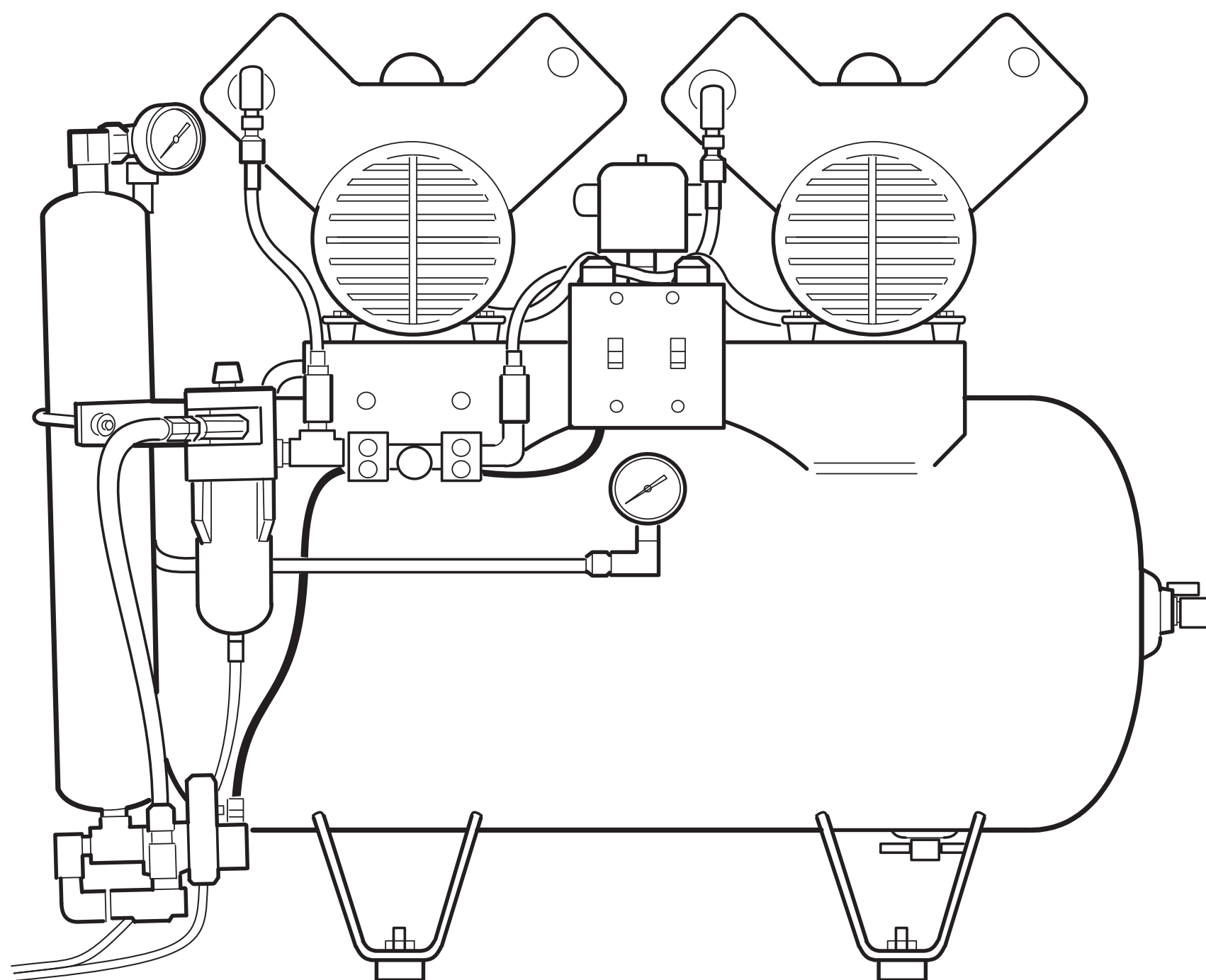

DCI Compressors

Site requirement guide for Model Numbers: C1103, C1203, C2106, C2206, C3210



Remote Air Intake:

1. Remote Air Intake: DCI Part #2033
Many local building codes require that air drawn into a compressed air system be taken in from outside of the building. In these cases, a DCI Remote Air Intake Kit is required.

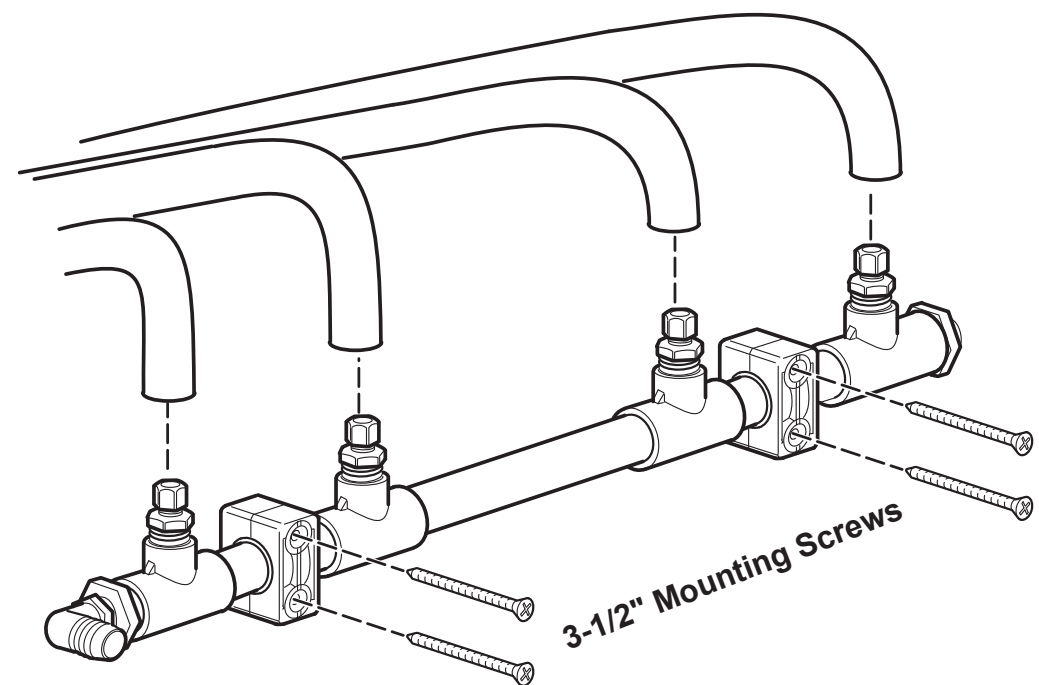

2. Plumbing requirements: Minimum 1-1/2" pipe run from outside of building to within 3 ft. of center back of air compressor. Per all applicable building codes.
3. As a means of ensuring that no foreign object or debris enters the outside piping, a DCI Part #2851 must be installed to protect the piping system from contaminants.

Plumbing Requirements:

1. 1/2 inch I.D. minimum pipe size.
2. Pipe connection is to be located within 3 ft. of center back of compressor.
3. Install per all local and state plumbing codes.

Air Hose Connection:

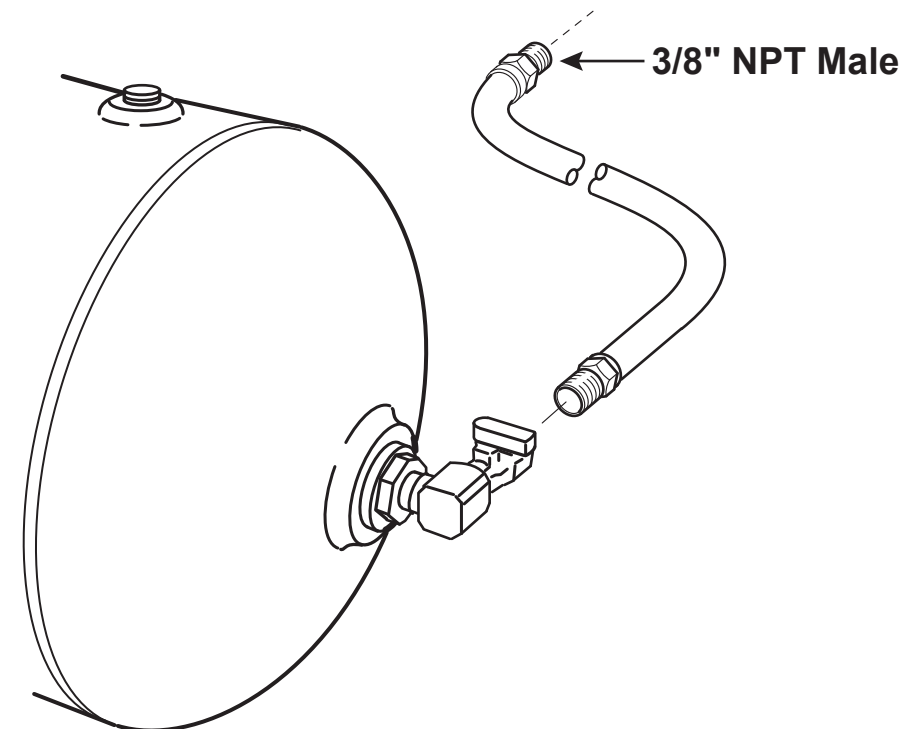

Dimensions:

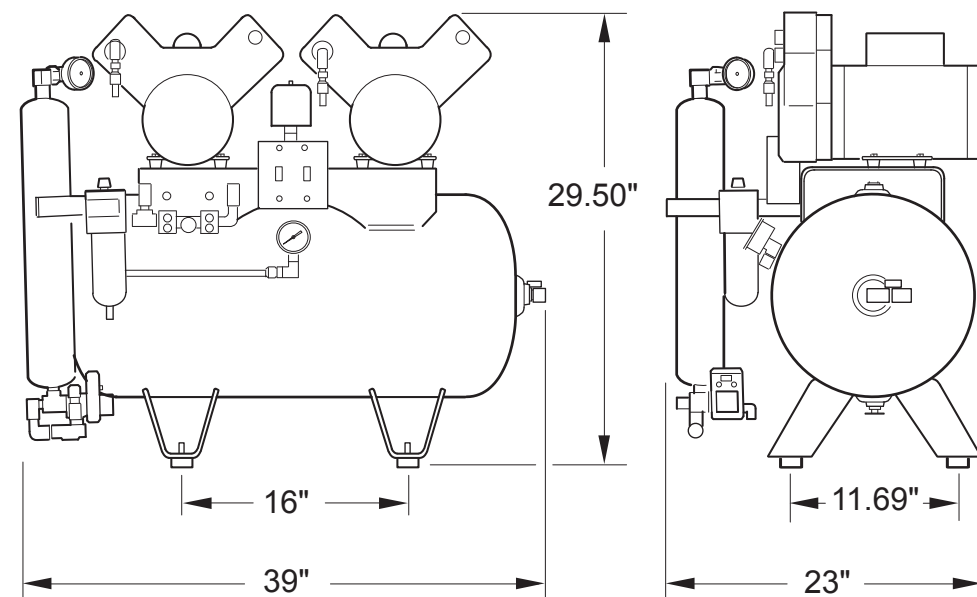

Low Voltage Controls:

Low Voltage Controls: DCI Part #2030
If the installation requires an operator to remotely switch the compressor on and off from a remote location, a low voltage control is needed. This device allows 24 VAC to control the line voltage supplied to the air compressor.

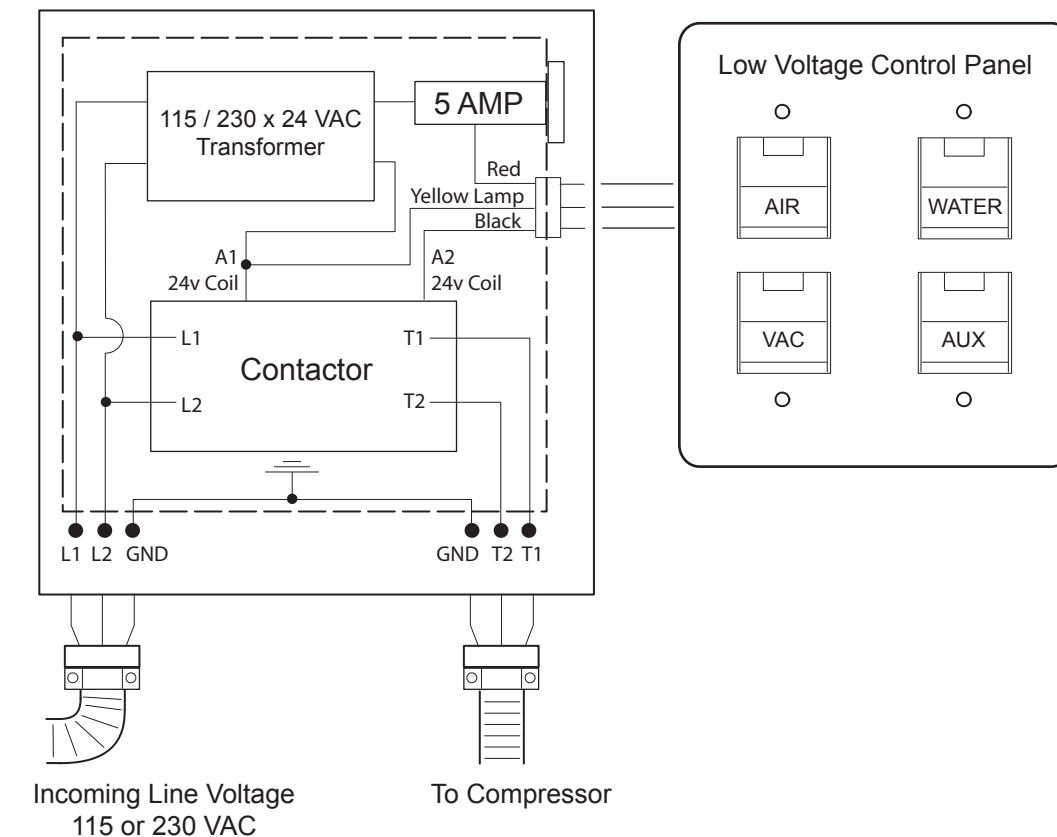

Electrical Requirements: Supply the applicable 115 or 230 VAC line voltage to Low Voltage Control on terminals L1, L2, and ground within 3 ft. of the center back of the air compressor. The power cable of the air compressor will connect to the Low Voltage Control Terminals marked T1, T2, and ground. Per all applicable building codes. Supply voltage must be 115 or 230 VAC ± 5%. If voltage is not within the range specified, contact DCI for technical assistance. There are 3 low voltage wires that must be routed to the Low Voltage Control Panel "Switch". These wires should be 16ga. Red / Black / & Yellow.

Low Voltage Control Panel:	
Single Switch Control Panel	DCI Part #2900
Dual Switch Control Panel	DCI Part #2901
Triple Switch Control Panel	DCI Part #2902
Quad Switch Control Panel	DCI Part #2904

Electrical Requirements: Three (3) 18ga. wires (1 RED), (1 BLACK), & (1 YELLOW) are required per switch. These wires should be run into a standard double gang electrical box located within 3 ft. of the center back of the air compressor and also where the switch panel is to be located. Per all applicable building codes.

Clearances:

