

# POTENTIOMETER AND SOFT LIMIT ADJUSTMENT



## UPPER POTENTIOMETER: SEAT BACK INCLINE-RECLINE (A-DEC®)

Starting Position – Cascade® 1040, Performer®  
Seat Back Fully **Reclined**

Starting Position – Decade® 1011/1021  
Seat Back Fully **Inclined**

Disconnect drive mechanism from potentiometer and remove old potentiometer, and then reinstall potentiometer into bracket. Prior to connecting drive mechanism:

On 1040 chair – Turn the potentiometer shaft **clockwise** until it will no longer turn. Then turn the shaft counterclockwise 1/8th of a turn and reconnect the drive shaft.

On 1021/Decade® chairs – Turn the potentiometer shaft **counterclockwise** until it will no longer turn. Then turn the shaft clockwise 1/8th of a turn and reconnect the drive shaft.

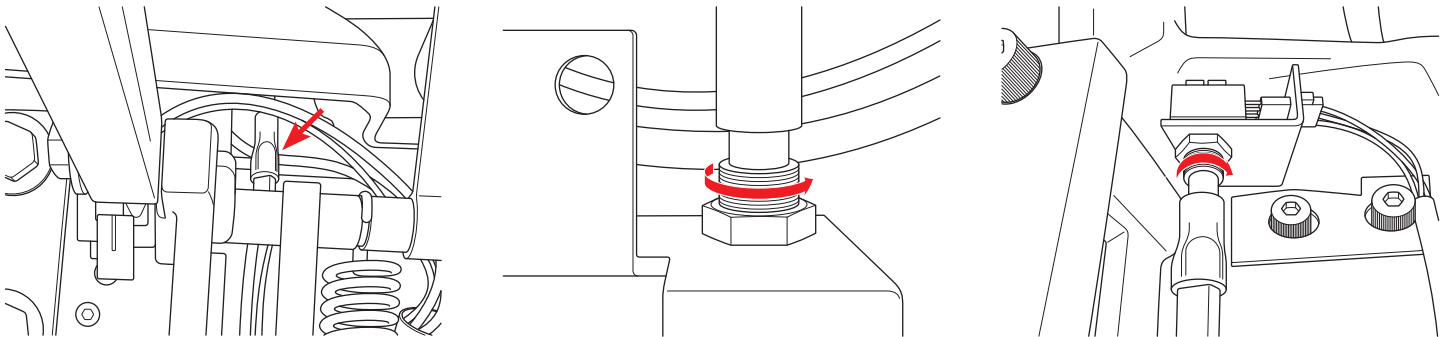

## LOWER POTENTIOMETER: BASE UP-DOWN (A-DEC® CASCADE®, DECADE®)

Starting Position  
Chair Fully **Lowered**

1. Remove the mounting screw from the assembly.
2. Rotate the potentiometer gear clockwise until rotation stops.
3. Align the potentiometer assembly, and then rotate the potentiometer gear counterclockwise two teeth relative to one tooth on the large drive gear.
4. Reinstall the mounting screw and verify that all the electrical connections to the limit switch and potentiometer are properly connected.

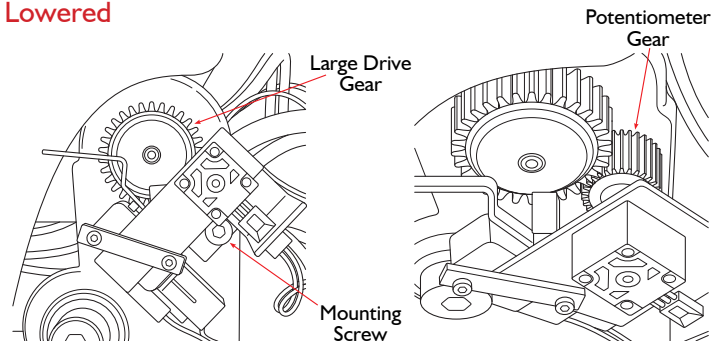

## UPPER POTENTIOMETER: SEAT BACK INCLINE-RECLINE (PELTON & CRANE)

Starting Position  
Seat Back Fully **Inclined**

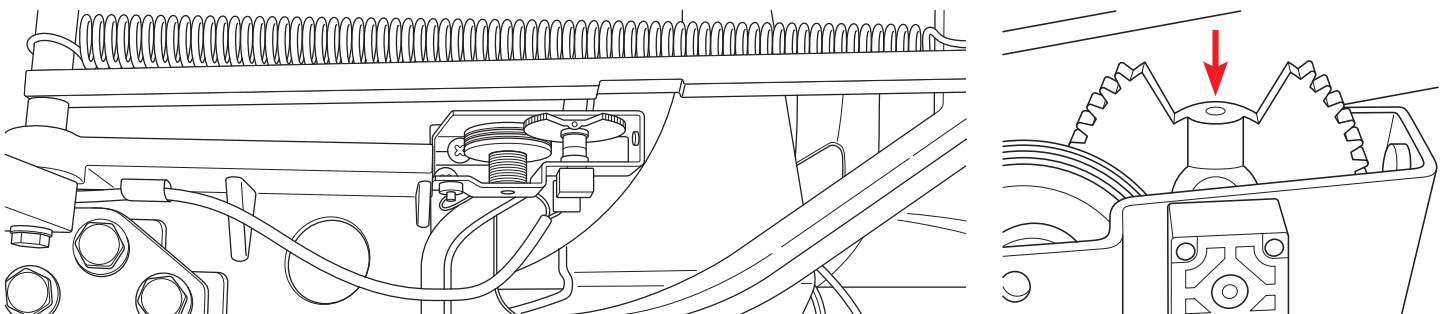

## LOWER POTENTIOMETER: BASE UP-DOWN (PELTON & CRANE)

Starting Position  
Chair Fully Lowered

1. Place a circuit jumper on the pins on Section 8 of the Terminal Strip.

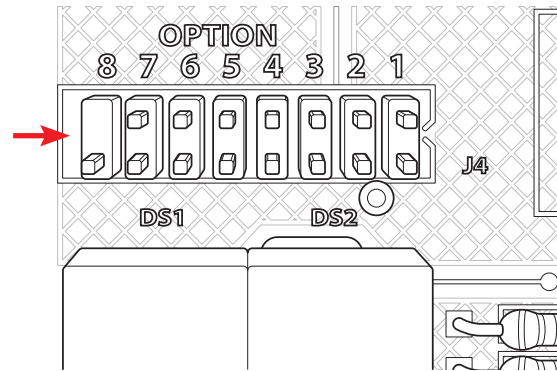
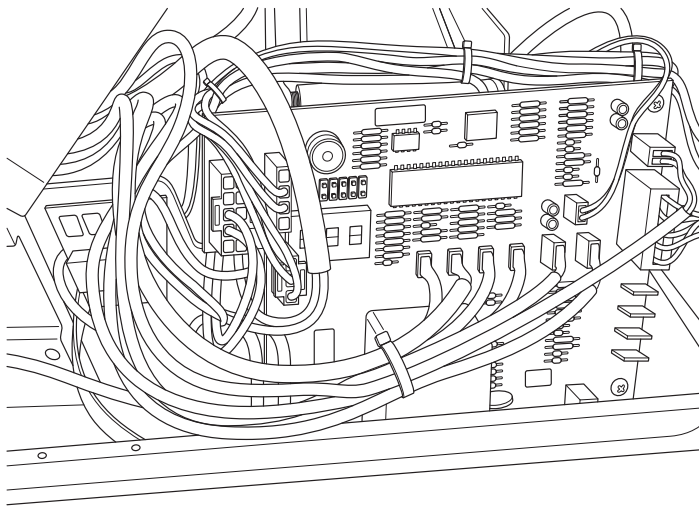

**NOTE:** After setting Base Up and Down, place the jumper on a single pin to prevent loss of the jumper.

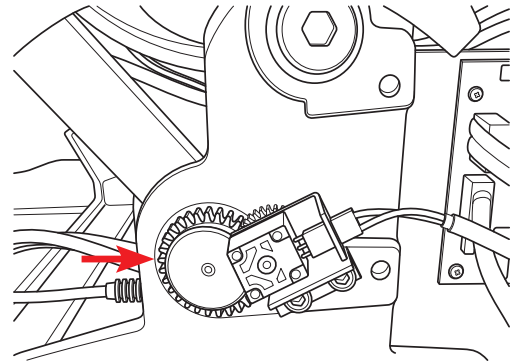

2. Loosen the set screw in the large gear.
3. With the chair plugged into power, turn the large gear counterclockwise until it stops.
4. Rotate the large gear clockwise two teeth.
5. Retighten the set screw to secure the adjustment.

## SETTING PELTON & CRANE SOFT LIMITS

Soft Limits must be set when the chair's potentiometers have been replaced or disturbed, thereby losing its calibration. Soft Limits control the Base and Seat Back minimum and maximum values.

With the circuit jumper on the pins on Section 8 of the Terminal Strip:

1. Raise the chair base up to a height of 23 5/8 in.
2. Press and hold the Learn Button on the chair's foot control and press the Base UP button on the foot control twice. (A single beep from the control board will confirm the set limit.)
3. Lower the chair base down to a height of 9 5/8 in.
4. Press and hold the Learn Button on the chair's foot control and press the Base Down button on the foot control twice. (A single beep from the control board will confirm the set limit.)
5. Recline the Seat Back to its lowest mechanical limit then Incline by 2 in.
6. Press and hold the Learn Button on the chair's foot control and press the Recline button on the foot control twice. (A single beep from the control board will confirm the set limit.)
7. Incline the Seat Back to its highest mechanical limit, and then Recline by 2 in.
8. Press and hold the Learn Button on the chair's foot control and press the Incline button on the foot control twice. (A single beep from the control board will confirm the set limit.)
9. Remove the circuit jumper from the terminal strip and cycle the chair manually through the limits to verify that the settings have been saved.

A-dec®, Cascade®, Performer® and Decade® are registered trademarks of A-dec, Inc. DCI has no affiliation with A-dec and A-dec has not authorized DCI replacement parts to be used on or in connection with A-dec® products.

