

DCI III MANUAL UNIT 4502

Installation and Operating Instructions



Package contains:

- Manual control unit with handpiece tubing and umbilical tubing
- Precision Comfort syringe
- Wet/Dry foot control
- Syringe repair kit

Tools needed:

- 1/4" and 1/8" sleeve tool
- Screwdriver or other appropriate hand tool for wall fasteners

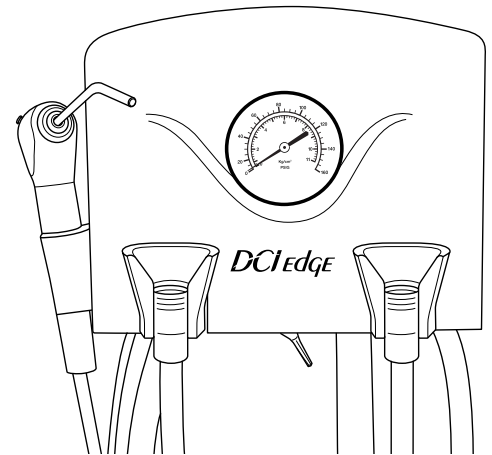

INSTALLATION INSTRUCTIONS

- 1. Cover:** Remove the screw retaining the cover to the chassis- located on the underside front using a 3/32" hex key. Lift cover up and remove from rear hinge.
- 2. Chassis:** Install unit chassis to wall using the two outside holes provided in the back of the chassis on a surface that will support the weight of the unit using appropriate fasteners for the material the unit is being mounted to. See Figure 1.
- 3. Umbilical tubing:** Run unit umbilical tubing's into junction box. Connect proper tubing's to utility center:
 - 1/8" Red - Water supply
 - 1/4" Gray - Regulated drive air/air coolant
 - 8 conductor low voltage power cord - as needed
- 4. Water and Air Supply:** Open the manual shut-off valves in the utility center. Adjust regulated air to 80 psi and regulated water to 40 psi. When adjusting for a lower pressure, make the adjustment, and then press the syringe button to relieve the pressure to get an accurate pressure reading.

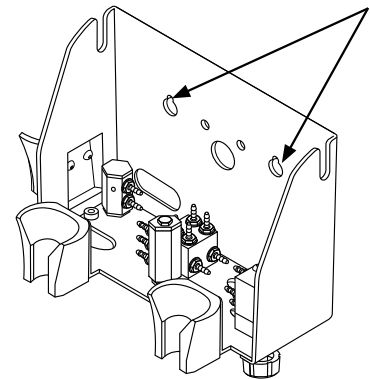
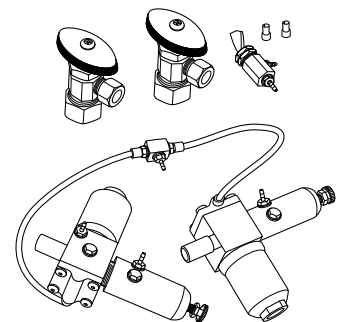

FIGURE 1



STEPS 3 - 4 UTILITY CENTER NOT INCLUDED

OPERATING INSTRUCTIONS AND UNIT FEATURES

HANDPIECE HOLDERS

The handpiece holders are designed to resist chemical discoloration and be easy to clean.

CONTROLS

Water coolant is only provided to handpiece #2. The handpiece #2 water on/off switch is located on the underside of the unit on the left. The water coolant flow control knob controls water to handpiece #2 and is located on the underside of the control unit, near the front on the right. The handpiece selector switch is located on the underside of the unit in between the handpiece tubing 1 and 2 - use this to toggle between handpiece #1 and handpiece #2. The drive air pressure gauge indicates the operating pressure of the selected handpiece. It is located in the center on the unit cover. The drive air adjustment screws are located on the underside of the control unit, in the back. Handpiece drive air pressure should be adjusted to the handpiece manufacturer's recommendation. See Figure 2.

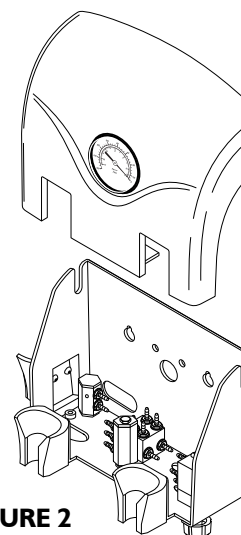
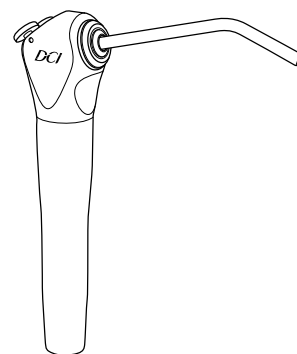

FIGURE 2

SYRINGE

The #4502 comes with a Precision Comfort syringe. The syringe is packaged in a shipping envelope, with operating instructions and a repair kit attached. The syringe goes in the holder on the far left side of the unit chassis. Adjustment screws for the air and water flow to the syringe are located on the underside of the control unit, in the rear left area. Use the 3/32" hex driver provided with the unit to turn the hex screws counterclockwise to increase the flow of air or water, clockwise to decrease the flow.



FOOT CONTROL

Handpiece speed is controlled with the foot control disc. Varying pressure on the foot control disc controls speed. Air coolant is also provided when you step on the foot control.

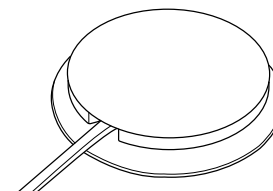

CONTROL HEAD

The control head can be cleaned with most commonly available surface disinfectants. Do not use any Sodium Hypochloride solutions, or any cleansers containing alcohol. These may cause paint and finish discoloration.

DENTAL UNIT WATER LINE MAINTENANCE

Distilled water is not recommended for use in dental units. The Center for Disease Control and the American Dental Association can provide recommendations on when to flush your system, for how long, and what products to use.

CLEANING AND MAINTENANCE

Do not use powdered cleansers, scouring pads, or abrasive scrubbers on any of the finished metal surfaces in this unit, i.e. the syringe or the foot control disc. Sodium Hypochloride will also damage these surfaces.