

SERIES 4 MANUAL UNIT 4528 & 4530

Installation and Operating Instructions



Package contains:

- 50" Flex arm 8733 white or 8735 Gray, Manual control unit with umbilical and tubing
- Precision Comfort syringe
- Foot control
- 2" Post collar
- Bearing strip kit
- Stainless steel tray with holder
- Syringe repair kit

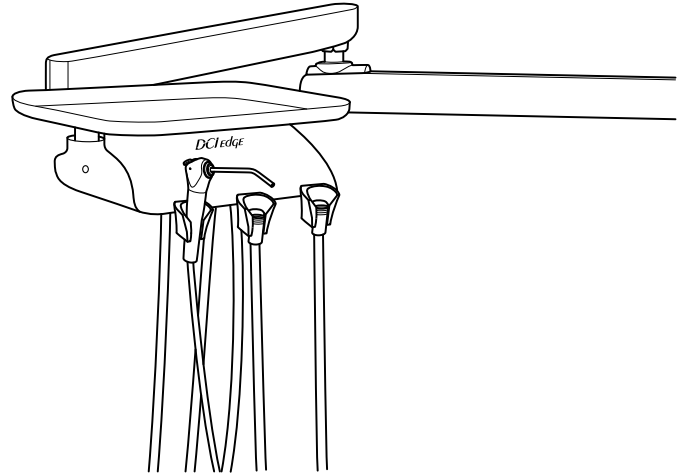

Tools needed:

- 1/4" and 1/8" sleeve tool
- Small and large flat blade screwdriver
- Post leveling tool

INSTALLATION INSTRUCTIONS



WARNING: The arm assembly for this control unit is spring loaded. Do not remove the shipping strap from the arm until the control unit is fully installed. Bodily injury could result from working with the arm assembly unrestrained.

1. **Post:** Install a 2" post in the chair adapter of the dental chair. Level the post utilizing the manufacturer's post leveling adjustments. To prevent unit drifting the post must be perfectly leveled.
2. **Collar:** Slide the collar onto the post to the desired height of the rigid section of the flex arm in relation to the seat of the chair. Tighten the 3 set screws in the side of the collar with a 3/32" hex key. **NOTE:** Some chair seats will raise as the patient is put in the supine position. Be sure to place the collar with the chair in this position. Slide the plastic washer on top of the collar.
3. **Unit Arm:** Slide the hub portion of the unit arm down the post on top of the collar. **NOTE:** Additional bearing strips are provided with different thicknesses due to variances in finish on the posts. Use appropriate bearing strips in the arm hub to provide smooth action with no hub to post play. Remove the shipping strap from the arm and unwrap.

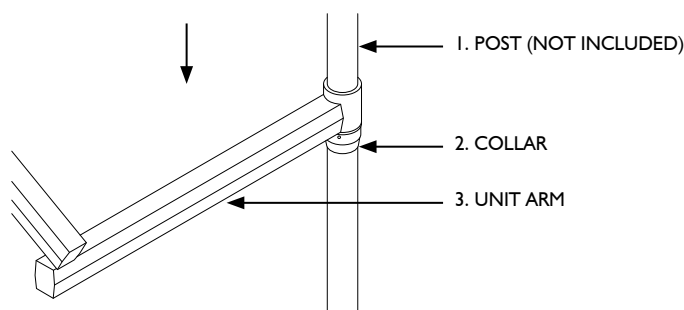

STEPS 1 - 3

4. **Umbilical Tubing:** Run unit umbilical tubing's either into post hole or directly into junction box at the base of the chair. Connect proper tubing's to utility center:

- 1/8" Red - Water supply
- 1/8" Gray - Regulated air
- 1/4" Gray - Regulated drive air/air coolant
- 8 conductor low voltage power cord - as needed

5. **Water and Air Supply:** Open the manual shutoff valves in the utility center. Adjust regulated air to 80 psi and regulated water to 40 psi. When adjusting for a lower pressure, make the adjustment, and then press the syringe button to relieve the pressure to get an accurate pressure reading.

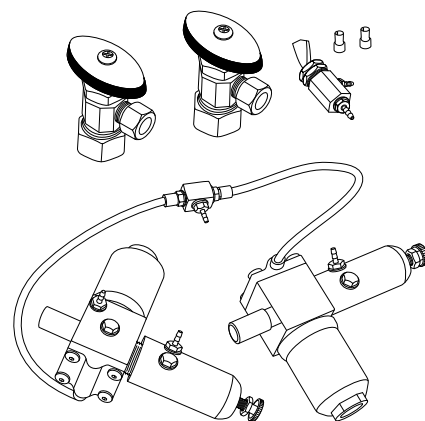

**STEPS 4 - 5 UTILITY CENTER
NOT INCLUDED**

OPERATING INSTRUCTIONS AND UNIT FEATURES

HANDPIECE HOLDERS

The handpiece holders are designed to resist chemical discoloration and be easy to clean.

CONTROLS

Water coolant is provided to handpiece #1 and #2. The handpiece *water coolant on/off switch* is located on the underside of the unit on the left. The *water coolant flow control knobs* control water to handpiece #1 and #2 respectively and are located on the underside of the control unit, near the back on the left. The *handpiece selector switch* is located on the underside of the unit in between the handpiece tubing 1 and 2 - use this to toggle between handpiece #1 and handpiece #2. The *drive air pressure gauge* indicates the operating pressure of the selected handpiece.

It is located on the right side of the control unit chassis. The *drive air adjustment screws* are located on the underside of the control unit, in the back. Handpiece drive air pressure should be adjusted to the handpiece manufacturer's recommendation. See Figure 1.

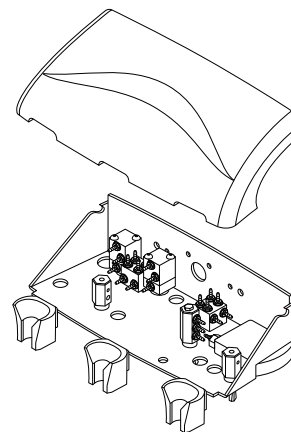
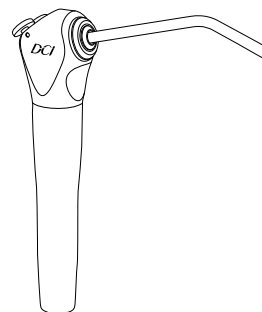

FIGURE 1

SYRINGE

The #4527 comes with a Precision Comfort syringe. The syringe is packaged in a shipping envelope, with operating instructions and a repair kit attached. The syringe goes in the holder on the far left side of the instrument holder bar. Adjustment screws for the air and water flow to the syringe are located on the underside of the control unit, in the rear left area. Use the 3/32" hex driver provided with the unit to turn the hex screws counterclockwise to increase the flow of air or water, clockwise to decrease the flow.



FOOT CONTROL

Handpiece speed is controlled with the foot control disc. Varying pressure on the foot control disc controls speed. Air coolant is also provided when you step on the foot control disc.

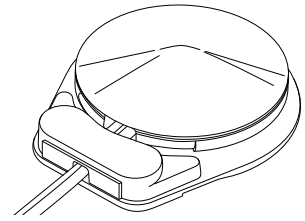

CONTROL HEAD

The control head can be cleaned with most commonly available surface disinfectants. Do not use any Sodium Hypochloride solutions, or any cleansers containing alcohol. These may cause paint and finish discoloration. To gain access to components, remove screw retaining cover using a 3/32" hex driver, lift cover up and remove from rear hinge.

DENTAL UNIT WATER LINE MAINTENANCE

Distilled water is not recommended for use in dental units. The Center for Disease Control and the American Dental Association can provide recommendations on when to flush your system, for how long, and what products to use.

CLEANING AND MAINTENANCE

Do not use powdered cleansers, scouring pads, or abrasive scrubbers on any of the finished metal surfaces in this unit, i.e., the syringe or the foot control disc. Sodium Hypochloride will also damage these surfaces.

FLEX ARM

The *pneumatic arm brake toggle* is located on the underside of the control unit, in the front right corner or front left corner- if unit is left handed. The brake keeps the vertical position of the arm assembly constant until the operator chooses to change it. To change the vertical position of the arm, pull the toggle forward to release the brake, reposition the arm to the desired position and release the toggle. It may be necessary to adjust the spring tension on the flex arm section of the pneumatic arm, depending on the extra weight added to the instrument tray. If the control unit drifts out of the vertical position when the brake is released extend the arm assembly fully and position it at its highest vertical height. Slide the long plastic strip out to expose the supply tubing running inside the arm (See Figure 2). The opening under the tubing provides access to the handle for the tension adjustment. The handle is located underneath the supply tubing and will present itself if the tubing is moved to one side. Spring tension is adjusted by moving the handle either to the left or the right. If the control unit drifts up, move the handle counterclockwise (as viewed from front of control unit) to reduce tension - disengage collar by moving handle toward the unit head - advance the handle and reengage - repeat until desired tension is achieved. If the control unit drifts down, move the handle clockwise (as viewed from front of control unit) to increase tension - disengage collar by moving handle toward the unit head - advance the handle and reengage - repeat until desired tension is achieved. Replace tubing back to original position and slide the long plastic strip back into place - the tension adjustment handle will fold out of the way automatically.

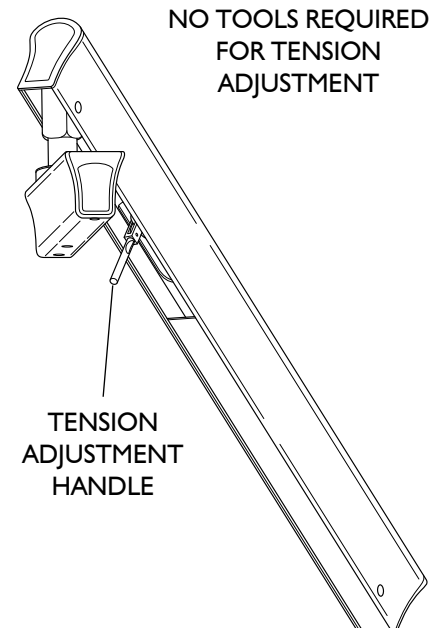

FIGURE 2

OPERATION OF FLEX ARM AND FEATURES

Adjustable pin stop: Rigid arm to flex section.

Factory set at the most common rotational stops. To adjust:

1. Slide cover up and twist at slotted area and slide over knuckle.
2. Rotate arm to gain access - remove pin and replace in desired rotational stop - there are 12 areas to place the stop.
3. Replace cover.

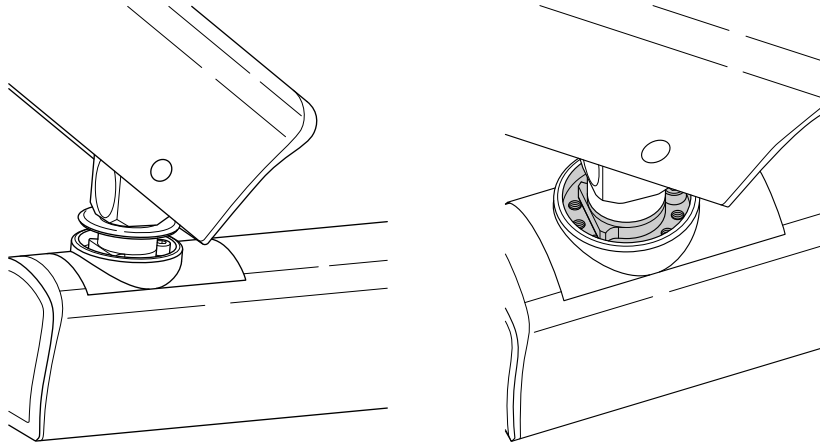

FIGURE 3. ADJUSTABLE PIN STOP: RIGID ARM TO FLEX SECTION

Adjustable pin stop: Flex section to small Unit Mount Rigid Arm.

Factory set at the most common rotational stops. To adjust:

1. Slide cover up and twist at slotted area and slide over knuckle.
2. Rotate arm to gain access - remove pin and replace in desired rotational stop - there are 12 areas to place the stop.
3. Replace cover.

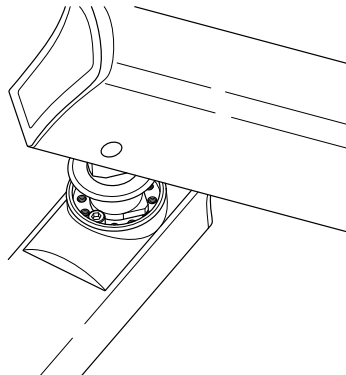

FIGURE 4. ADJUSTABLE PIN STOP: FLEX SECTION TO SMALL UNIT MOUNT RIGID ARM