

SWING MOUNT SYSTEM

Installation Instructions

DCI **EDGE**

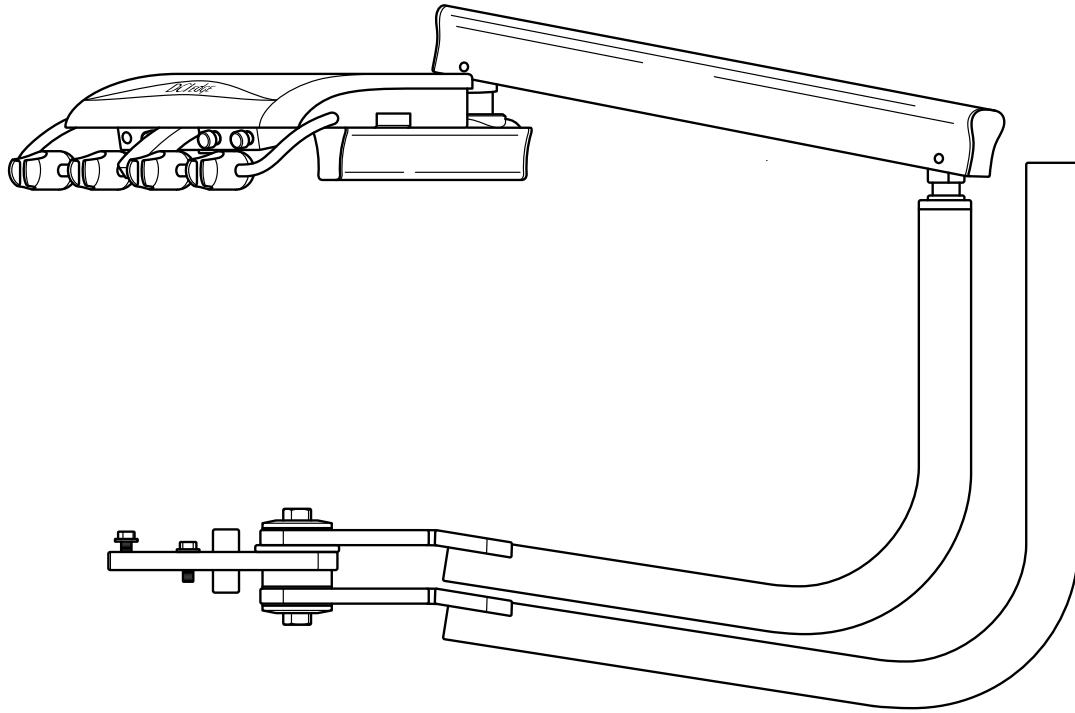

Table of Contents	Page
Unit Installation Notes	2
Swing Mount to Chair Adaptor Installation	3
Delivery System Installation	4
Junction Box Utility Connections - Notes	5
Delivery System to Utility Center Installation	6
Flex Arm Adjustments	7
Pole Leveling/Flex Arm Drift	8
Utility Center Adjustments/Syringe and Handpiece Flow	9

UNIT INSTALLATION NOTES

BEFORE YOU BEGIN

- Study the Unit Overview in this booklet and Layout Dimensions from the Owner's Manual. Make sure the planned location will have the necessary space available for installation, including room for travel of the chair's base and backrest.
- Open all containers and review the contents. It may be helpful to locate all kits containing accessories. (Smaller parts are often packaged together to avoid being lost.)
- Locate all documentation supplied with the package. Manuals and installation sheets may be found in one or more boxes accompanying their respective components. Set aside the Owner's Manual for the end user to review.
- If a complete ensemble is to be installed, set up the chair first. Refer to the installation manual supplied with the chair for instructions.
- In all configurations, the unit pole, unit flex arm, and unit control head come shipped as a complete assembly. In some of the following illustrations, only the unit pole may be shown for clarity.

SYMBOLS USED IN THIS MANUAL

The following symbols may be used throughout this product manual:

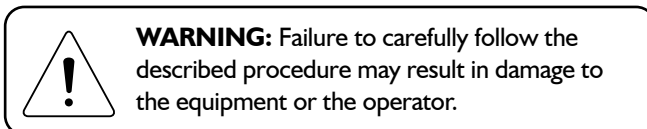
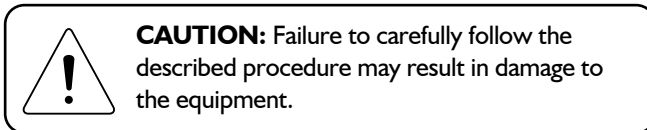

SPECIAL TEXT FORMATTING

To simplify installation, this manual is formatted to highlight references to necessary parts or tools:

- Parts that need to be located during assembly are shown in **bold**.
- Tools that are required for each step are shown underlined.

SUGGESTED TOOLS

- 9/16" wrench, socket or open end
- 5/8" wrench, open end
- 7/16" wrench, open end
- 15/16" wrench, open end
- Standard size hex wrench set (some Keys will be included with ensemble)
- Magnetic level, 6 to 12 inches long
- Scissors or utility knife
- Wire strippers
- Flathead screwdriver, small
- Phillips screwdriver, small
- Pail for excess water

SWING MOUNT TO CHAIR ADAPTER INSTALLATION

1. Refer to **Swing Mount Adapter Installation Instructions** (included in literature kit) for adapter installation.
2. Locate the mounting hardware (**Flanged Bolts Qty. 4**). **NOTE:** Flanged Bolts are included with the adapter assembly. Refer to **Swing Mount Adapter Installation Instructions**.
3. Start two of the flanged bolts in the back of the chair adapter, leave approximately 1" of clearance for the pivot plate thickness.

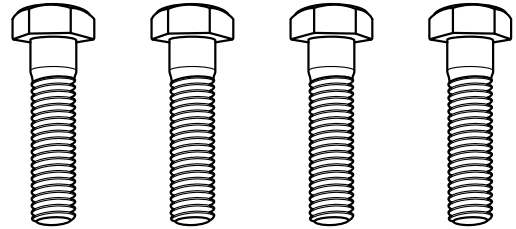

NOTE: For A-dec® Priority®, the bolts MUST be installed from the bottom of the chair adapter.

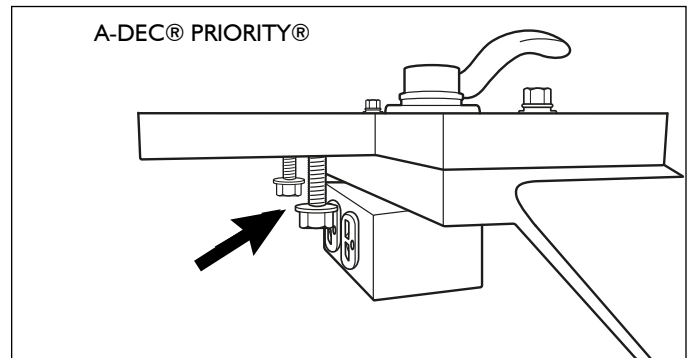
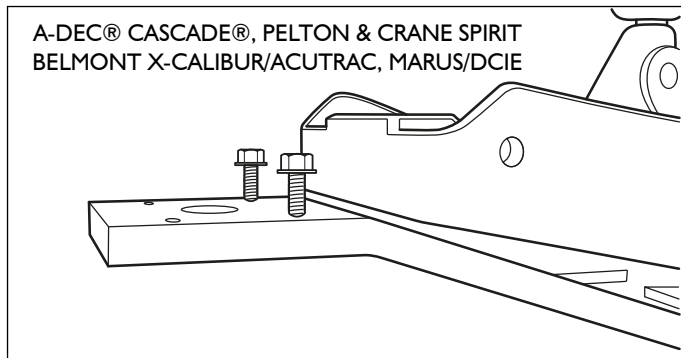

4. Remove the **Swing Mount Pole Assembly** from the packaging and slide the pivot plate into the flanged bolts.

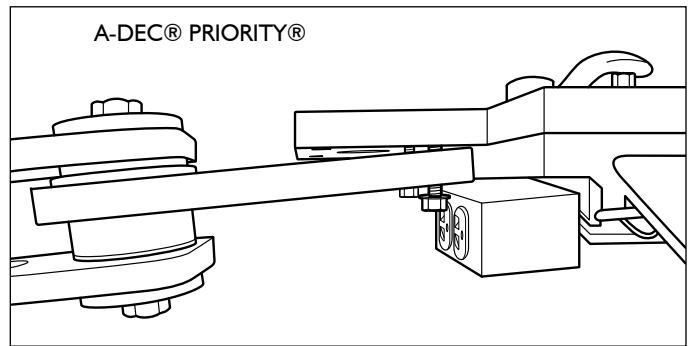
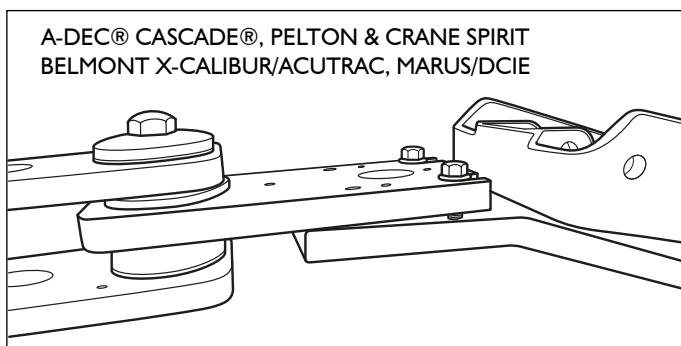

5. Install the remaining bolts to the corresponding holes in the adapter and tighten all four bolts with a 9/16" wrench or socket.

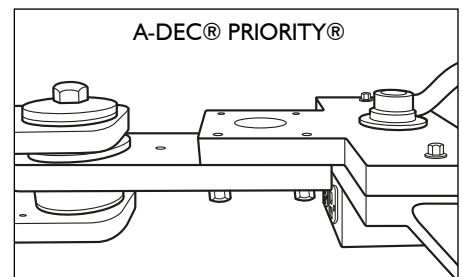
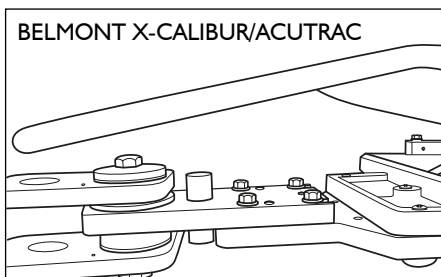
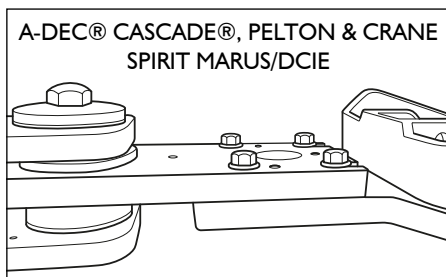

DELIVERY SYSTEM INSTALLATION

1. Remove the **Delivery System** from the packaging.
2. Feed the umbilical through the unit pole with the self contained water system.

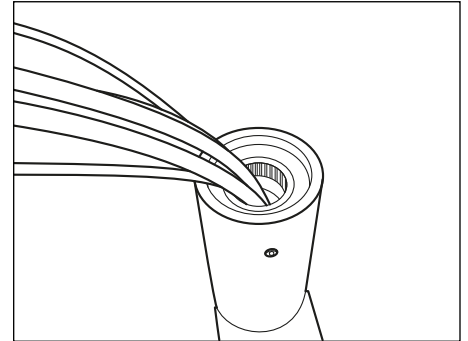
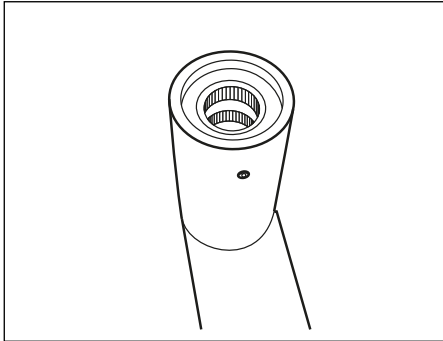
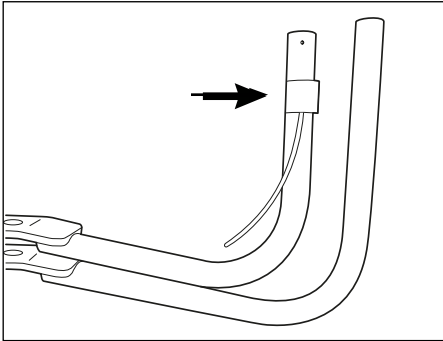

3. Complete Delivery System installation with the full insertion of the flex arm knuckle into the top of the unit pole.

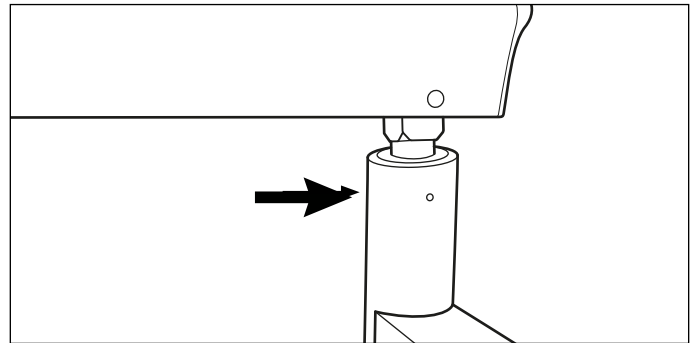
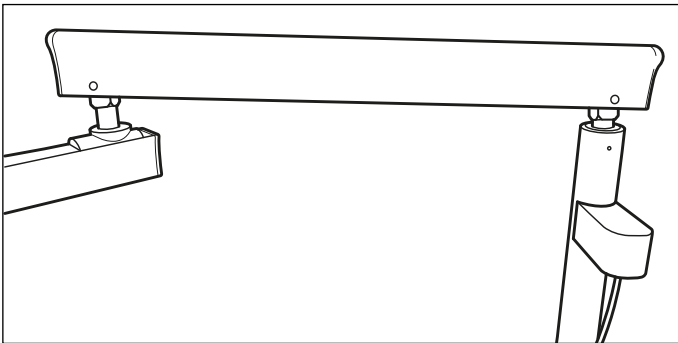

4. Connect the Red tubing from the self contained water system umbilical to the Red tubing from the delivery system umbilical with the supplied 1/16" In-Line barb and 1/8" sleeves.

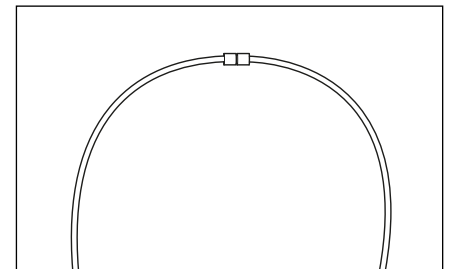
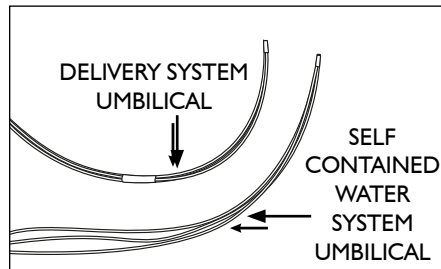

5. Slide the supplied **Poly Knit Sleeve** (snakeskin) over the umbilical. Route the umbilical under the chair adapter and through the chair to the floor utilities.

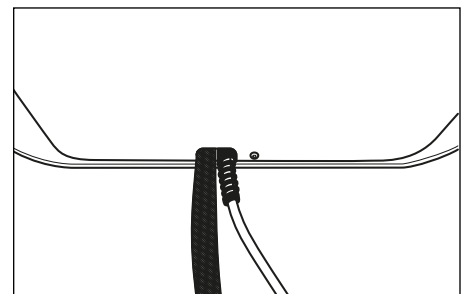
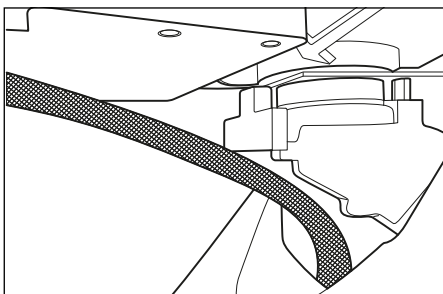
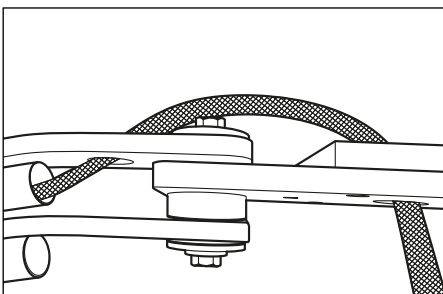

JUNCTION BOX UTILITY CONNECTIONS - NOTES

- Local regulations may require that licensed plumbers and electricians install utilities.
- Make sure all plumbing conforms to prevailing local codes.
- Use the junction box template to determine floor locations for connections.

AIR:

- 1/2" pipe N.P.T. protruding 1" from floor or wall. Supplied by contractor.
- Manual air shut off valve to be installed by contractor.
- Air pressure 80 - 100 psi.
- Air plumbing should be flushed clean before making final connections to dental equipment.

WATER:

- 1/2" pipe N.P.T. protruding 1" from floor or wall. Supplied by contractor.
- Manual water shut off valve to be installed by contractor.
- Water pressure 40 - 80 psi.
- Water plumbing should be flushed clean before making final connections to dental equipment.

ELECTRICAL:

- 1/2" conduit and box with quad or equal receptacle supplied by contractor.
- Wire box as per code with the top of the box no higher than 4-1/2" above the finished floor.
- Voltage: 115 Volts AC 3 wire or
230 Volts AC 3 wire.

CENTRAL VACUUM:

- Plumbing up to the utility center should be specified by center vacuum supplier and terminated in the utility center with 5/8" OD tubing perpendicular to the floor, similar to the drain connection.

GRAVITY DRAIN:

- 5/8" OD tubing protruding 1" from the finished floor.

NOTE: Place trap in line and use a vented fitting to conform with local codes. Supplied by contractor.

- Floor mounting only.

DELIVERY SYSTEM TO UTILITY CENTER INSTALLATION

1. Place the junction box frame over the floor stub ups (electrical, vac, air, water, etc.).
2. Connect the shut-off block to the compressed air and water supply manual shut-off valves.

NOTE 1: The Yellow side is for air.

NOTE 2: The air and water supply lines must be flushed prior to connection to the shut-off block.

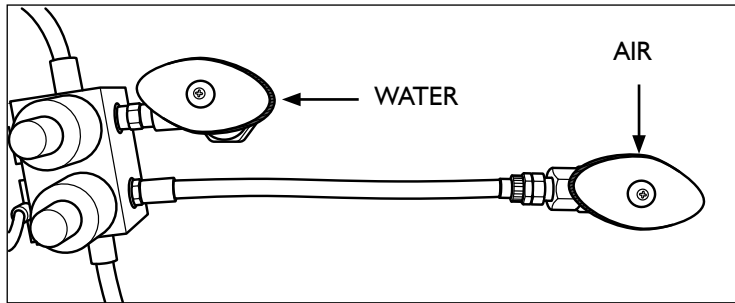

3. Connect the umbilical tubings to the appropriate connection points, including foot control rheostat, with supplied In-Line barbs and Sleeves.

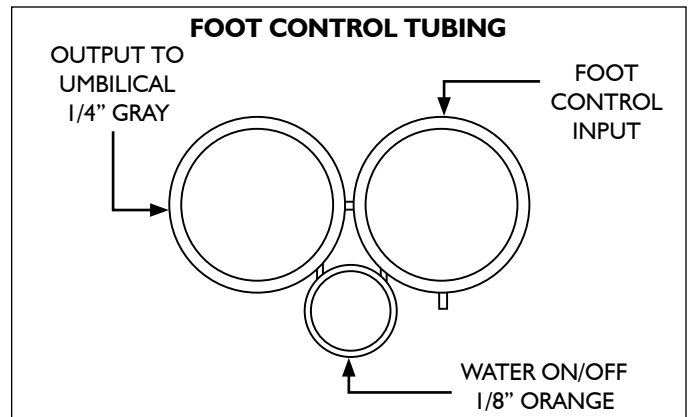
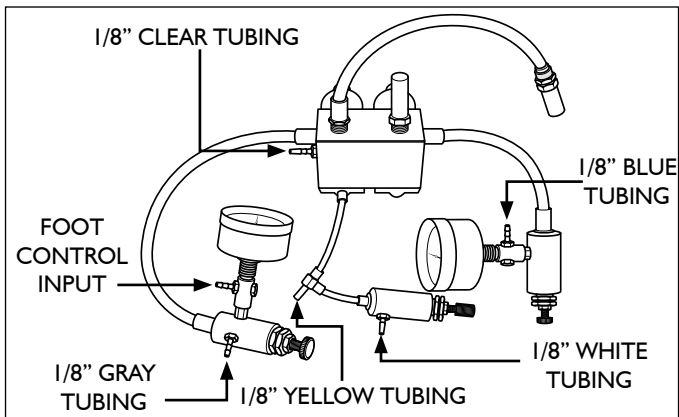

4. Install the Air and Water Regulators to the J-Box frame with a 9/16" wrench.

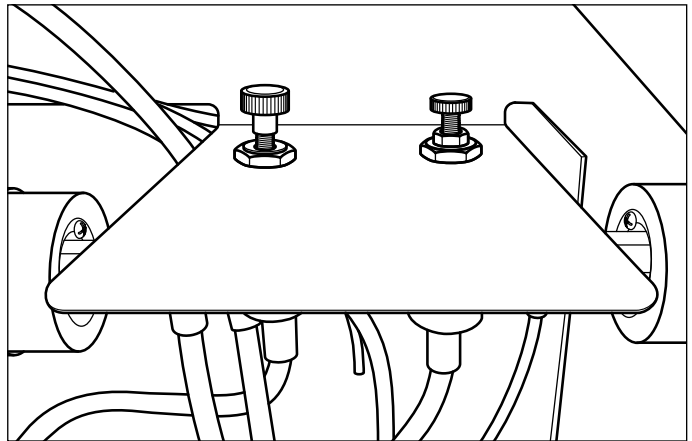
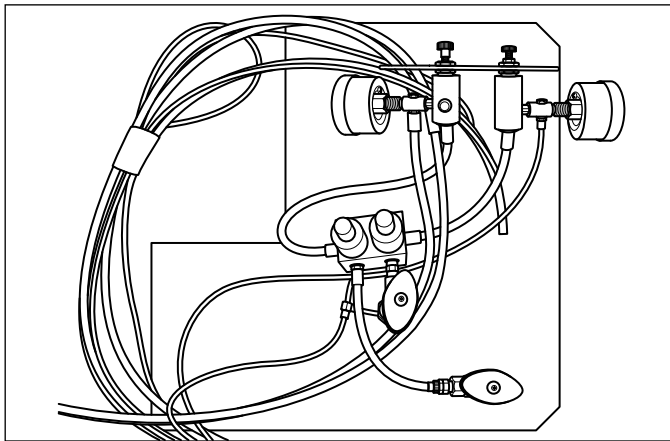

5. Once all connections have been made and the water bottle is installed, open the air and water valves then turn on the dental unit via "Master On/Off" on the control head. Check all connection points for leaks.
6. Place the junction box cover over the frame so the two parts "snap" together. Ensure that there isn't any tubing protruding from the sides of the junction box.

FLEX ARM ADJUSTMENTS

1. The Flex arm is preset at the factory however you may need to adjust to the user's needs.
2. Raise the chair and the flex arm as high as possible for ease of access.
3. Slide the "belly strip" out from under the arm exposing the umbilical tubing.

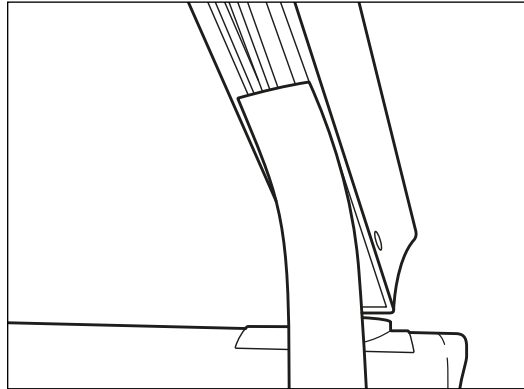

4. Locate the Tension Adjustment Handle towards the upper section of the flex arm.

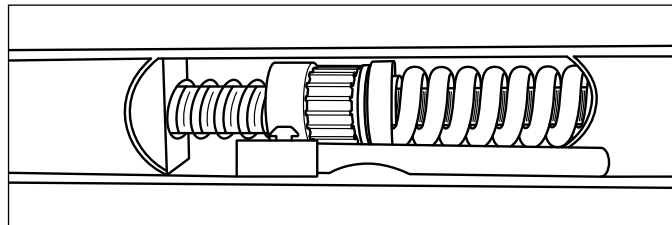

5. Hold the tubing out and to the side.
6. Use the handle to turn the Star Nut by sliding it into the nut and turning, then slide out and reposition each turn. Note-Turning the Star Nut clockwise tightens the spring thus making the arm able to hold more load.

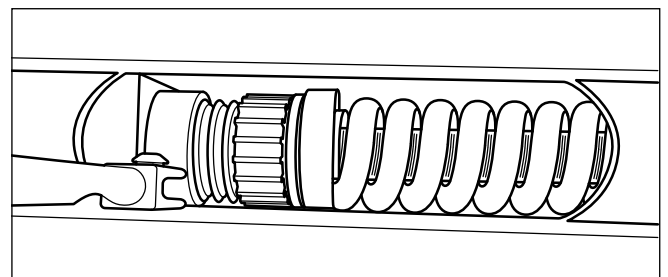
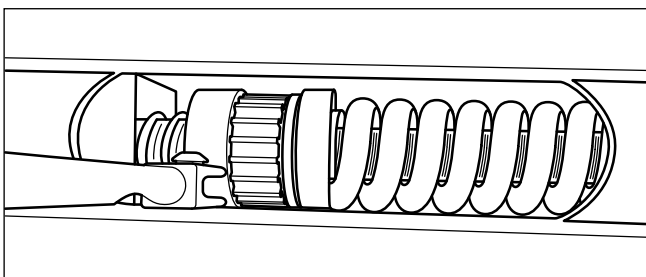
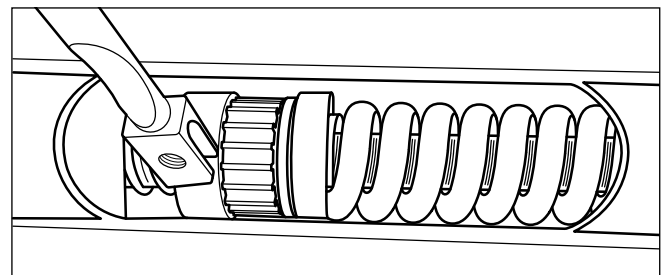
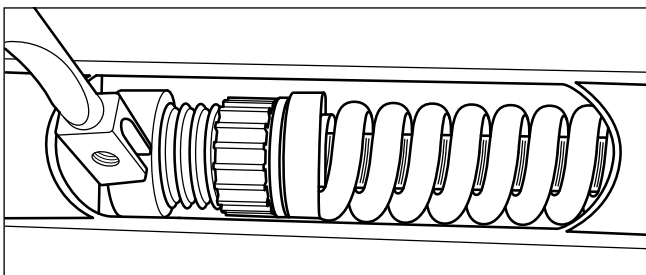

7. Replace the belly strip and position once complete.

POLE LEVELING

1. There are three leveling screws on the top of the pivot plate.

NOTE: For the A-dec® Priority®, the leveling screws are on the bottom of the pivot plate.

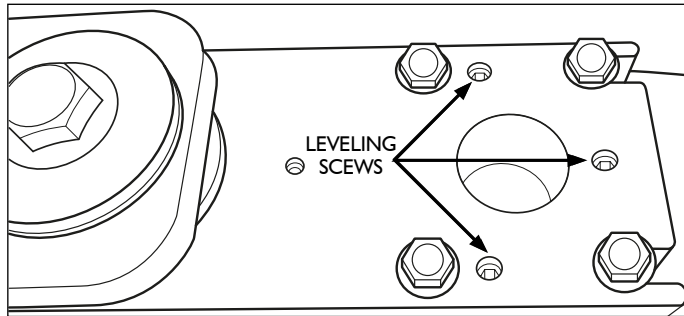

2. Loosen the four flanged bolts that secure the pivot plate to the chair adapter with a 9/16" wrench.
3. Place a post level on either the unit pole or the light pole.
4. Adjust the leveling screws with a 3/16" hex key to desired position and retighten the flanged bolts.

FLEX ARM DRIFT

1. Increase or decrease flex arm drift by tightening or loosening the set screw in the unit pole above water system cover with a 3/32" hex key.

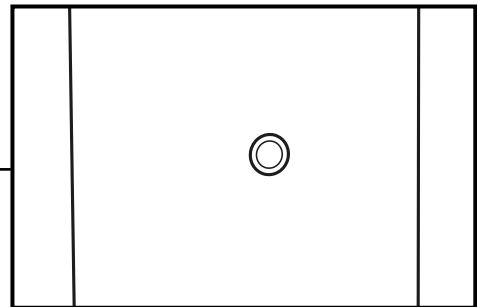
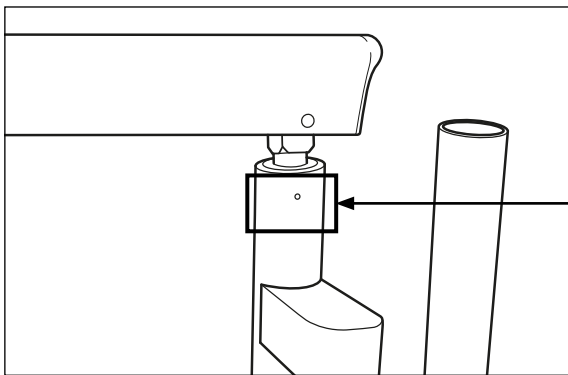

Pivot bolts are factory set to 50 ft. lbs. of torque. Do not attempt to adjust these bolts as damage to the equipment and/or user may result.

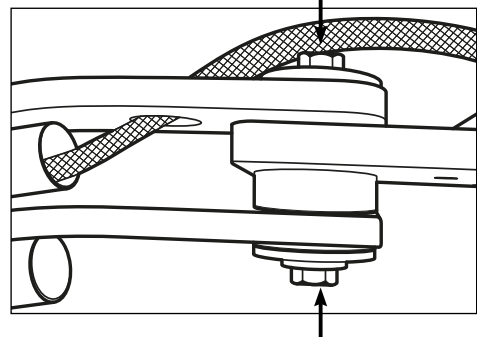

UTILITY CENTER ADJUSTMENTS

1. The air and water floor regulators with shut-offs are factory preset at 40psi for city water and 80psi for air.
2. The air and water floor regulators are controlled by the master switch on the unit to activate and deactivate. Ensure Master On/Off is "On" when adjusting the regulators.
3. Locate the adjustment screw on the end of the regulator. Tightening will increase the pressure and loosening will decrease the pressure. If decreasing the pressure, bleed off line pressure via the syringe.

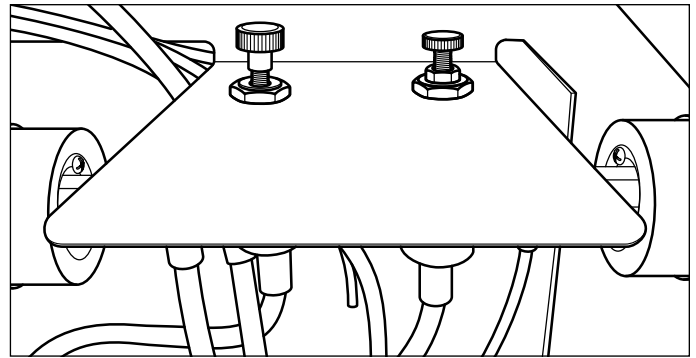
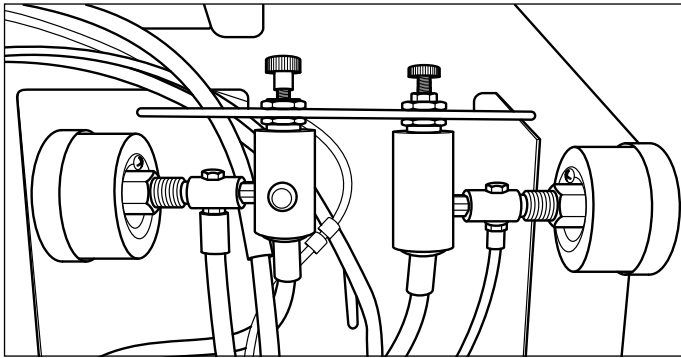

SYRINGE AND HANDPIECE FLOW

1. Open the unit head cover by removing the retaining screw under the center of the holder bar snout.
2. Locate the syringe block and adjust the flow with the two adjustment screws to desired rate with a $3/32$ " hex key.

SYRINGE CONTROL BLOCK

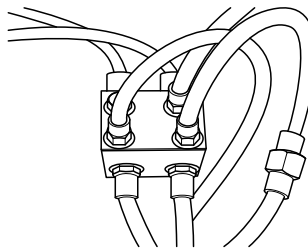

ADJUSTMENT SCREWS

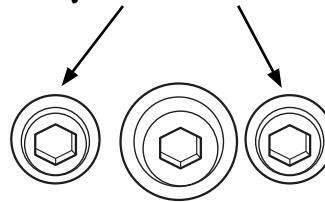

3. Locate the handpiece block and adjust each handpiece limit to desired speed with the corresponding adjustment screw (tighten to increase speed, loosen to decrease speed).
4. Replace unit cover and secure with the retaining screw.

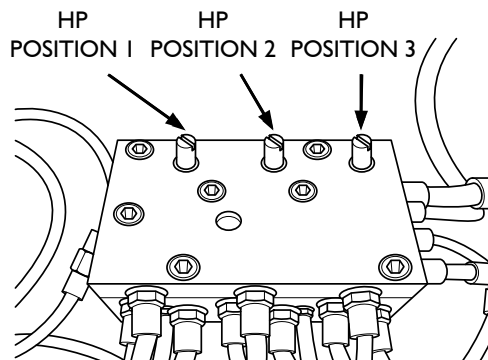

A-dec®, Cascade® and Priority® are registered trademarks of A-dec, Inc. DCI has no affiliation with A-dec and A-dec has not authorized DCI replacement parts to be used on or in connection with A-dec® products.

